



COMMONWEALTH OF PENNSYLVANIA
DEPARTMENT OF ENVIRONMENTAL PROTECTION
AIR QUALITY PROGRAM

TITLE V/STATE OPERATING PERMIT

Issue Date: February 10, 2023 Effective Date: May 30, 2023
Revision Date: May 30, 2023 Expiration Date: February 29, 2028
Revision Type: Modification

In accordance with the provisions of the Air Pollution Control Act, the Act of January 8, 1960, P.L. 2119, as amended, and 25 Pa. Code Chapter 127, the Owner, [and Operator if noted] (hereinafter referred to as permittee) identified below is authorized by the Department of Environmental Protection (Department) to operate the air emission source(s) more fully described in this permit. This Facility is subject to all terms and conditions specified in this permit. Nothing in this permit relieves the permittee from its obligations to comply with all applicable Federal, State and Local laws and regulations.

The regulatory or statutory authority for each permit condition is set forth in brackets. All terms and conditions in this permit are federally enforceable applicable requirements unless otherwise designated as "State-Only" or "non-applicable" requirements.

TITLE V Permit No: 22-05012

Federal Tax Id - Plant Code: 85-4084783-1

Owner Information

Name: CLEVELAND-CLIFFS STEELTON LLC
Mailing Address: 215 S FRONT ST
STEELTON, PA 17113-2538

Plant Information

Plant: CLEVELAND CLIFFS STEELTON LLC/STEELTON
Location: 22 Dauphin County 22003 Steelton Borough
SIC Code: 3312 Manufacturing - Blast Furnaces And Steel Mills

Responsible Official

Name: BILL CARLISLE
Title: GEN MGR - STEELTON
Phone: (717) 986 - 2269 Email: Bill.Carlisle@clevelandcliffs.com

Permit Contact Person

Name: TRENT TAGESSEN
Title: ENV ENG
Phone: (717) 986 - 2574 Email: trenton.tagessen@clevelandcliffs.com

[Signature] _____
WILLIAM R. WEAVER, SOUTHCENTRAL REGION AIR PROGRAM MANAGER

**SECTION A. Table of Contents****Section A. Facility/Source Identification**

Table of Contents
Site Inventory List

Section B. General Title V Requirements

- #001 Definitions
- #002 Prohibition of Air Pollution
- #003 Property Rights
- #004 Permit Expiration
- #005 Permit Renewal
- #006 Transfer of Ownership or Operational Control
- #007 Inspection and Entry
- #008 Compliance Requirements
- #009 Need to Halt or Reduce Activity Not a Defense
- #010 Duty to Provide Information
- #011 Reopening and Revising the Title V Permit for Cause
- #012 Reopening a Title V Permit for Cause by EPA
- #013 Operating Permit Application Review by the EPA
- #014 Significant Operating Permit Modifications
- #015 Minor Operating Permit Modifications
- #016 Administrative Operating Permit Amendments
- #017 Severability Clause
- #018 Fee Payment
- #019 Authorization for De Minimis Emission Increases
- #020 Reactivation of Sources
- #021 Circumvention
- #022 Submissions
- #023 Sampling, Testing and Monitoring Procedures
- #024 Recordkeeping Requirements
- #025 Reporting Requirements
- #026 Compliance Certification
- #027 Operational Flexibility
- #028 Risk Management
- #029 Approved Economic Incentives and Emission Trading Programs
- #030 Permit Shield
- #031 Reporting
- #032 Report Format

Section C. Site Level Title V Requirements

- C-I: Restrictions
- C-II: Testing Requirements
- C-III: Monitoring Requirements
- C-IV: Recordkeeping Requirements
- C-V: Reporting Requirements
- C-VI: Work Practice Standards
- C-VII: Additional Requirements
- C-VIII: Compliance Certification
- C-IX: Compliance Schedule

Section D. Source Level Title V Requirements

- D-I: Restrictions
- D-II: Testing Requirements
- D-III: Monitoring Requirements
- D-IV: Recordkeeping Requirements
- D-V: Reporting Requirements



SECTION A. Table of Contents

D-VI: Work Practice Standards
D-VII: Additional Requirements

Note: These same sub-sections are repeated for each source!

Section E. Source Group Restrictions

E-I: Restrictions
E-II: Testing Requirements
E-III: Monitoring Requirements
E-IV: Recordkeeping Requirements
E-V: Reporting Requirements
E-VI: Work Practice Standards
E-VII: Additional Requirements

Section F. Alternative Operating Scenario(s)

F-I: Restrictions
F-II: Testing Requirements
F-III: Monitoring Requirements
F-IV: Recordkeeping Requirements
F-V: Reporting Requirements
F-VI: Work Practice Standards
F-VII: Additional Requirements

Section G. Emission Restriction Summary

Section H. Miscellaneous

**SECTION A. Site Inventory List**

Source ID	Source Name	Capacity/Throughput		Fuel/Material
032A	BOILER (ZURN, 14M-350)	99.000	MMBTU/HR	
		99.000	MCF/HR	Natural Gas
		709.300	Gal/HR	#2 Oil
035A	BOILER (YORK-SHIPLEY, 582-SPH-650-XID)	27.700	MMBTU/HR	
		27.700	MCF/HR	Natural Gas
		196.400	Gal/HR	#2 Oil
033	PLANT HOT WATER HEATERS	9.900	MCF/HR	Natural Gas
034	SHOP SPACE HEATERS	30.000	MCF/HR	Natural Gas
102	CONTROLLED COOLING BOXES 1 - 8	250.000	Tons/HR	STEEL RAILS
		4.600	MCF/HR	NATURAL GAS
109	EAF LADLE PREHEATERS 1-4	9.600	MCF/HR	NATURAL GAS
113	BURN OFF OVEN	0.500	MCF/HR	Natural Gas
114	CONTIN. CASTER TUNDISH PREHTR. 1 & 2	19.900	MCF/HR	Natural Gas
116	CONTINUOUS CASTER TUNDISH DRYER 1	4.600	MCF/HR	Natural Gas
118	CASTER CUTTING TORCHES 1-6	4.600	MCF/HR	NATURAL GAS
124	CASTER VENTS	250.000	Tons/HR	STEEL
129	RAILROAD CAR INGOT HEATERS	17.900	MCF/HR	Natural Gas
130	INGOT TEEMING	150.000	Tons/HR	STEEL
131	VACUUM DEGASSER AT INGOT TEEMING	150.000	Tons/HR	STEEL
132A	44" MILL HOT ROLLING OPERATIONS	250.000	Tons/HR	STEEL
132B	28"/35" MILL HOT ROLLING OPERATIONS	250.000	Tons/HR	STEEL
132C	20" MILL HOT ROLLING OPERATIONS	250.000	Tons/HR	STEEL
137	RAIL STENCILING	2.000	Lbs/HR	INK
138	SCRAP PREPARATION	31.300	Tons/HR	SCRAP STEEL
		11.200	MCF/HR	NATURAL GAS
140	MOTOR VEHICLE FUELING			
232C	20" MILL REHEAT FURNACE	250.000	Tons/HR	STEEL
		180.000	MCF/HR	NATURAL GAS
301	35" MILL REHEAT FURNACES 3 & 4	116.000	Tons/HR	STEEL
		80.000	MCF/HR	NATURAL GAS
311	WALKING BEAM REHEAT FURNACE, DANIELI/EQUIVALENT, 421MMBTU/HR	180.000	Tons/HR	STEEL
		421.700	MCF/HR	Natural Gas
311A	WBF EMERGENCY GENERATOR	49.000	Gal/HR	Diesel Fuel
401	SOAKING PIT BATTERIES 4-6	125.000	Tons/HR	STEEL
		175.000	MCF/HR	NATURAL GAS
500	VACUUM DEGASSER @ STEELMAKING	150.000	Tons/HR	STEEL
501A	#207 DCEAF	163.000	Tons/HR	STEEL
		93.000	MCF/HR	NATURAL GAS
501B	LADLE REFINING FURNACE	163.000	Tons/HR	STEEL
504	COAL STORAGE SILO		N/A	COAL
505	COAL STORAGE SILO		N/A	SPAR COAL

**SECTION A. Site Inventory List**

Source ID	Source Name	Capacity/Throughput	Fuel/Material
510	#2 BAGHOUSE DUST PNEUMATIC SYSTEM	N/A	IRON OXIDE DUST
511	LIME INJECTION SILO	N/A	LIME
513	LIME SILO, LRF		
514	SODA ASH STORAGE SILO, SO2		
921	PARTS WASHERS	N/A	SOLVENT
922	COMPRESSED AIR SYSTEM FREEZE PROTECTION		
924	ROAD DUST EMISSIONS		
926A	WATER TREATMENT, BLR/PROC/VACDEG/CASTER		
C02	CONTROL, #2 BAGHOUSE		
C501B	CONTROL, SO2 DRY SCRUBBER, LRF		
C504	CONTROL, COAL STORAGE SILO		
C505	CONTROL, COAL STORAGE SILO		
C510	CONTROL, #2 BAGHOUSE DUST PNEUM. SYS.		
C511	CONTROL, LIME INJECTION SILO		
C513	CONTROL, LIME SILO, LRF		
C514	CONTROL, SODA ASH SILO, SO2		
FM002	NATURAL GAS LINE		
FM003	#2 FUEL OIL		
FM004	DIESEL		
S07	STACK, SOAKING PIT 4		
S08	STACK, SOAKING PIT 5		
S09	STACK, SOAKING PIT 6		
S11	STACK, BAGHOUSE 2		
S113	STACK, BURN OFF OVEN		
S124	STACK, CASTER VENT		
S19	STACK, 20" MILL REHEAT FURN		
S311	STACK, WBF		
S311A	WBF EMERGENCY GENERATOR STACK		
S32A	STACK, NEW BOILER		
S35A	STACK, BOILER (YORK-SHIPLEY)		
S40	STACK, VACUUM DEGASSER 500		
S41	STACK, VACUUM DEGASSER 131		
S42	STACK, VACUUM DEGASSER 131		
S43	STACK, 35" MILL REHT FURN		
S44	STACK, 35" MILL REHT FURN		
Z04	FUGITIVE		
Z05	FUGITIVE		
Z102	FUGITIVE		
Z11	FUGITIVE		
Z114	FUGITIVE		

**SECTION A. Site Inventory List**

Source ID	Source Name	Capacity/Throughput	Fuel/Material
Z13	FUGITIVE		
Z14	FUGITIVE		
Z140	VEHICLE FUELING FUGITIVES (GASOLINE)		
Z15	FUGITIVE		
Z37	FUGITIVE		
Z38	FUGITIVE		
Z510	FUGITIVE		
Z511	FUGITIVE		
Z921	FUGITIVE		
Z924	FUGITIVE		
Z926	FUGITIVE		

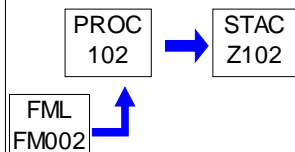
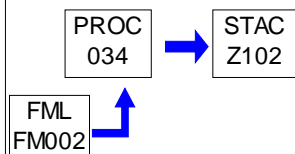
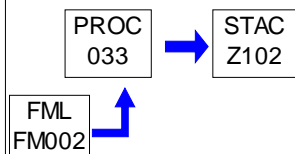
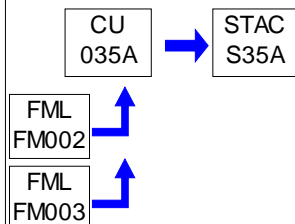
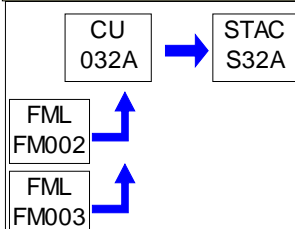
PERMIT MAPS



PERMIT MAPS

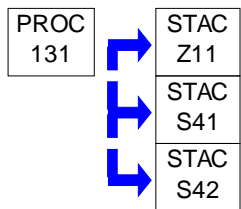
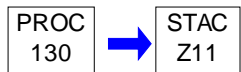
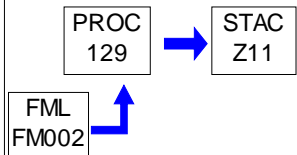
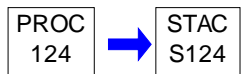
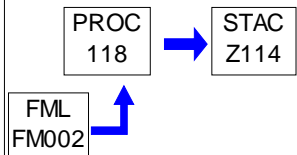
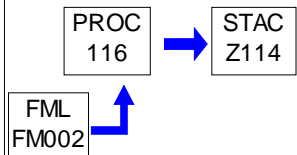
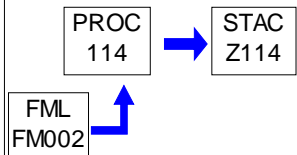
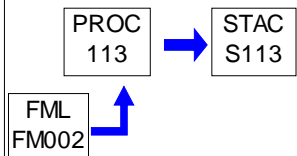
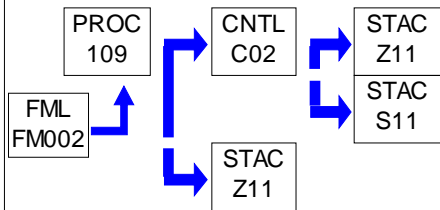



PERMIT MAPS

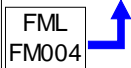
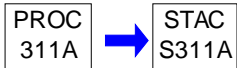
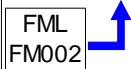
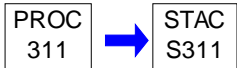
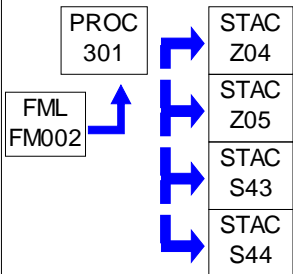
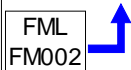
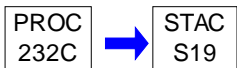
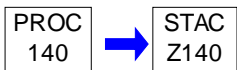
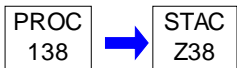
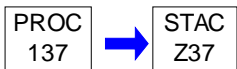
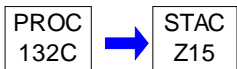
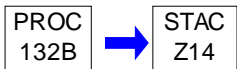
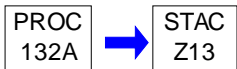



PERMIT MAPS

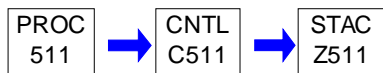
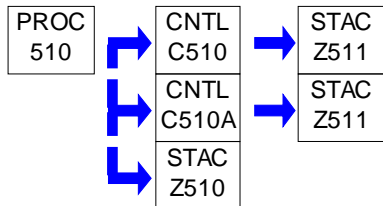
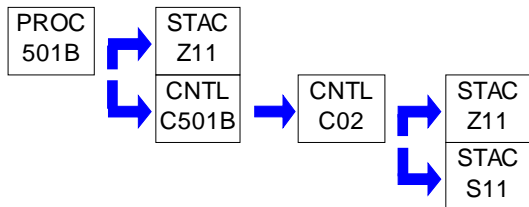
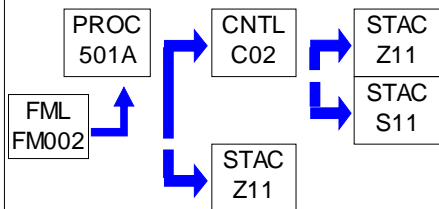
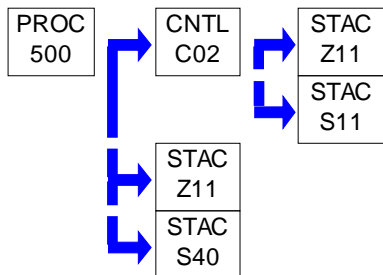
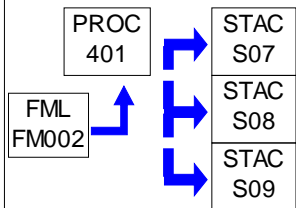

**PERMIT MAPS**

PROC 514 → CNTL C514 → STAC Z511

PROC 921 → STAC Z921

PROC 922 → STAC Z921

PROC 924 → STAC Z924

PROC 926A → STAC Z926

**SECTION B. General Title V Requirements****#001 [25 Pa. Code § 121.1]****Definitions**

Words and terms that are not otherwise defined in this permit shall have the meanings set forth in Section 3 of the Air Pollution Control Act (35 P.S. § 4003) and 25 Pa. Code § 121.1.

#002 [25 Pa. Code § 121.7]**Prohibition of Air Pollution**

No person may permit air pollution as that term is defined in the act.

#003 [25 Pa. Code § 127.512(c)(4)]**Property Rights**

This permit does not convey property rights of any sort, or any exclusive privileges.

#004 [25 Pa. Code § 127.446(a) and (c)]**Permit Expiration**

This operating permit is issued for a fixed term of five (5) years and shall expire on the date specified on Page 1 of this permit. The terms and conditions of the expired permit shall automatically continue pending issuance of a new Title V permit, provided the permittee has submitted a timely and complete application and paid applicable fees required under 25 Pa. Code Chapter 127, Subchapter I and the Department is unable, through no fault of the permittee, to issue or deny a new permit before the expiration of the previous permit. An application is complete if it contains sufficient information to begin processing the application, has the applicable sections completed and has been signed by a responsible official.

#005 [25 Pa. Code §§ 127.412, 127.413, 127.414, 127.446(e), 127.503 & 127.704(b)]**Permit Renewal**

(a) An application for the renewal of the Title V permit shall be submitted to the Department at least six (6) months, and not more than 18 months, before the expiration date of this permit. The renewal application is timely if a complete application is submitted to the Department's Regional Air Manager within the timeframe specified in this permit condition.

(b) The application for permit renewal shall include the current permit number, the appropriate permit renewal fee, a description of any permit revisions and off-permit changes that occurred during the permit term, and any applicable requirements that were promulgated and not incorporated into the permit during the permit term. The fees shall be made payable to "The Commonwealth of Pennsylvania Clean Air Fund" and submitted with the fee form to the respective regional office.

(c) The renewal application shall also include submission of proof that the local municipality and county, in which the facility is located, have been notified in accordance with 25 Pa. Code § 127.413. The application for renewal of the Title V permit shall also include submission of compliance review forms which have been used by the permittee to update information submitted in accordance with either 25 Pa. Code § 127.412(b) or § 127.412(j).

(d) The permittee, upon becoming aware that any relevant facts were omitted or incorrect information was submitted in the permit application, shall promptly submit such supplementary facts or corrected information during the permit renewal process. The permittee shall also promptly provide additional information as necessary to address any requirements that become applicable to the source after the date a complete renewal application was submitted but prior to release of a draft permit.

#006 [25 Pa. Code §§ 127.450(a)(4) & 127.464(a)]**Transfer of Ownership or Operational Control**

(a) In accordance with 25 Pa. Code § 127.450(a)(4), a change in ownership or operational control of the source shall be treated as an administrative amendment if:

- (1) The Department determines that no other change in the permit is necessary;
- (2) A written agreement has been submitted to the Department identifying the specific date of the transfer of permit responsibility, coverage and liability between the current and the new permittee; and,
- (3) A compliance review form has been submitted to the Department and the permit transfer has been approved by

**SECTION B. General Title V Requirements**

the Department.

(b) In accordance with 25 Pa. Code § 127.464(a), this permit may not be transferred to another person except in cases of transfer-of-ownership which are documented and approved to the satisfaction of the Department.

#007 [25 Pa. Code § 127.513, 35 P.S. § 4008 and § 114 of the CAA]**Inspection and Entry**

(a) Upon presentation of credentials and other documents as may be required by law for inspection and entry purposes, the permittee shall allow the Department of Environmental Protection or authorized representatives of the Department to perform the following:

- (1) Enter at reasonable times upon the permittee's premises where a Title V source is located or emissions related activity is conducted, or where records are kept under the conditions of this permit;
- (2) Have access to and copy or remove, at reasonable times, records that are kept under the conditions of this permit;
- (3) Inspect at reasonable times, facilities, equipment including monitoring and air pollution control equipment, practices, or operations regulated or required under this permit;
- (4) Sample or monitor, at reasonable times, substances or parameters, for the purpose of assuring compliance with the permit or applicable requirements as authorized by the Clean Air Act, the Air Pollution Control Act, or the regulations promulgated under the Acts.

(b) Pursuant to 35 P.S. § 4008, no person shall hinder, obstruct, prevent or interfere with the Department or its personnel in the performance of any duty authorized under the Air Pollution Control Act.

(c) Nothing in this permit condition shall limit the ability of the EPA to inspect or enter the premises of the permittee in accordance with Section 114 or other applicable provisions of the Clean Air Act.

#008 [25 Pa. Code §§ 127.25, 127.444, & 127.512(c)(1)]**Compliance Requirements**

(a) The permittee shall comply with the conditions of this permit. Noncompliance with this permit constitutes a violation of the Clean Air Act and the Air Pollution Control Act and is grounds for one (1) or more of the following:

- (1) Enforcement action
- (2) Permit termination, revocation and reissuance or modification
- (3) Denial of a permit renewal application

(b) A person may not cause or permit the operation of a source, which is subject to 25 Pa. Code Article III, unless the source(s) and air cleaning devices identified in the application for the plan approval and operating permit and the plan approval issued to the source are operated and maintained in accordance with specifications in the applications and the conditions in the plan approval and operating permit issued by the Department. A person may not cause or permit the operation of an air contamination source subject to 25 Pa. Code Chapter 127 in a manner inconsistent with good operating practices.

(c) For purposes of Sub-condition (b) of this permit condition, the specifications in applications for plan approvals and operating permits are the physical configurations and engineering design details which the Department determines are essential for the permittee's compliance with the applicable requirements in this Title V permit.

#009 [25 Pa. Code § 127.512(c)(2)]**Need to Halt or Reduce Activity Not a Defense**

It shall not be a defense for a permittee in an enforcement action that it would have been necessary to halt or reduce the permitted activity in order to maintain compliance with the conditions of this permit.

**SECTION B. General Title V Requirements****#010 [25 Pa. Code §§ 127.411(d) & 127.512(c)(5)]****Duty to Provide Information**

(a) The permittee shall furnish to the Department, within a reasonable time, information that the Department may request in writing to determine whether cause exists for modifying, revoking and reissuing, or terminating the permit, or to determine compliance with the permit.

(b) Upon request, the permittee shall also furnish to the Department copies of records that the permittee is required to keep by this permit, or for information claimed to be confidential, the permittee may furnish such records directly to the Administrator of EPA along with a claim of confidentiality.

#011 [25 Pa. Code §§ 127.463, 127.512(c)(3) & 127.542]**Reopening and Revising the Title V Permit for Cause**

(a) This Title V permit may be modified, revoked, reopened and reissued or terminated for cause. The filing of a request by the permittee for a permit modification, revocation and reissuance, or termination, or of a notification of planned changes or anticipated noncompliance does not stay a permit condition.

(b) This permit may be reopened, revised and reissued prior to expiration of the permit under one or more of the following circumstances:

(1) Additional applicable requirements under the Clean Air Act or the Air Pollution Control Act become applicable to a Title V facility with a remaining permit term of three (3) or more years prior to the expiration date of this permit. The Department will revise the permit as expeditiously as practicable but not later than 18 months after promulgation of the applicable standards or regulations. No such revision is required if the effective date of the requirement is later than the expiration date of this permit, unless the original permit or its terms and conditions has been extended.

(2) Additional requirements, including excess emissions requirements, become applicable to an affected source under the acid rain program. Upon approval by the Administrator of EPA, excess emissions offset plans for an affected source shall be incorporated into the permit.

(3) The Department or the EPA determines that this permit contains a material mistake or inaccurate statements were made in establishing the emissions standards or other terms or conditions of this permit.

(4) The Department or the Administrator of EPA determines that the permit must be revised or revoked to assure compliance with the applicable requirements.

(c) Proceedings to revise this permit shall follow the same procedures which apply to initial permit issuance and shall affect only those parts of this permit for which cause to revise exists. The revision shall be made as expeditiously as practicable.

(d) Regardless of whether a revision is made in accordance with (b)(1) above, the permittee shall meet the applicable standards or regulations promulgated under the Clean Air Act within the time frame required by standards or regulations.

#012 [25 Pa. Code § 127.543]**Reopening a Title V Permit for Cause by EPA**

As required by the Clean Air Act and regulations adopted thereunder, this permit may be modified, reopened and reissued, revoked or terminated for cause by EPA in accordance with procedures specified in 25 Pa. Code § 127.543.

#013 [25 Pa. Code § 127.522(a)]**Operating Permit Application Review by the EPA**

The applicant may be required by the Department to provide a copy of the permit application, including the compliance plan, directly to the Administrator of the EPA. Copies of title V permit applications to EPA, pursuant to 25 PA Code §127.522(a), shall be submitted, if required, to the following EPA e-mail box:

R3_Air_Apps_and_Notices@epa.gov

Please place the following in the subject line: TV [permit number], [Facility Name].

**SECTION B. General Title V Requirements****#014 [25 Pa. Code § 127.541]****Significant Operating Permit Modifications**

When permit modifications during the term of this permit do not qualify as minor permit modifications or administrative amendments, the permittee shall submit an application for significant Title V permit modifications in accordance with 25 Pa. Code § 127.541. Notifications to EPA, pursuant to 25 PA Code §127.522(a), if required, shall be submitted, to the following EPA e-mail box:

R3_Air_Apps_and_Notices@epa.gov

Please place the following in the subject line: TV [permit number], [Facility Name].

#015 [25 Pa. Code §§ 121.1 & 127.462]**Minor Operating Permit Modifications**

The permittee may make minor operating permit modifications (as defined in 25 Pa. Code §121.1), on an expedited basis, in accordance with 25 Pa. Code §127.462 (relating to minor operating permit modifications). Notifications to EPA, pursuant to 25 PA Code §127.462(c), if required, shall be submitted, to the following EPA e-mail box:

R3_Air_Apps_and_Notices@epa.gov

Please place the following in the subject line: TV [permit number], [Facility Name].

#016 [25 Pa. Code § 127.450]**Administrative Operating Permit Amendments**

(a) The permittee may request administrative operating permit amendments, as defined in 25 Pa. Code §127.450(a). Copies of request for administrative permit amendment to EPA, pursuant to 25 PA Code §127.450(c)(1), if required, shall be submitted to the following EPA e-mail box:

R3_Air_Apps_and_Notices@epa.gov

Please place the following in the subject line: TV [permit number], [Facility Name].

(b) Upon final action by the Department granting a request for an administrative operating permit amendment covered under §127.450(a)(5), the permit shield provisions in 25 Pa. Code § 127.516 (relating to permit shield) shall apply to administrative permit amendments incorporated in this Title V Permit in accordance with §127.450(c), unless precluded by the Clean Air Act or the regulations thereunder.

#017 [25 Pa. Code § 127.512(b)]**Severability Clause**

The provisions of this permit are severable, and if any provision of this permit is determined by the Environmental Hearing Board or a court of competent jurisdiction, or US EPA to be invalid or unenforceable, such a determination will not affect the remaining provisions of this permit.

#018 [25 Pa. Code §§ 127.704, 127.705 & 127.707]**Fee Payment**

(a) The permittee shall pay fees to the Department in accordance with the applicable fee schedules in 25 Pa. Code Chapter 127, Subchapter I (relating to plan approval and operating permit fees). The applicable fees shall be made payable to "The Commonwealth of Pennsylvania Clean Air Fund" with the permit number clearly indicated and submitted to the respective regional office.

(b) Emission Fees. The permittee shall, on or before September 1st of each year, pay applicable annual Title V emission fees for emissions occurring in the previous calendar year as specified in 25 Pa. Code § 127.705. The permittee is not required to pay an emission fee for emissions of more than 4,000 tons of each regulated pollutant emitted from the facility.

(c) As used in this permit condition, the term "regulated pollutant" is defined as a VOC, each pollutant regulated under Sections 111 and 112 of the Clean Air Act and each pollutant for which a National Ambient Air Quality Standard has been promulgated, except that carbon monoxide is excluded.

**SECTION B. General Title V Requirements**

(d) Late Payment. Late payment of emission fees will subject the permittee to the penalties prescribed in 25 Pa. Code § 127.707 and may result in the suspension or termination of the Title V permit. The permittee shall pay a penalty of fifty percent (50%) of the fee amount, plus interest on the fee amount computed in accordance with 26 U.S.C.A. § 6621(a)(2) from the date the emission fee should have been paid in accordance with the time frame specified in 25 Pa. Code § 127.705(c).

(e) The permittee shall pay an annual operating permit maintenance fee according to the following fee schedule established in 25 Pa. Code § 127.704(d) on or before December 31 of each year for the next calendar year.

(1) Eight thousand dollars (\$8,000) for calendar years 2021—2025.

(2) Ten thousand dollars (\$10,000) for calendar years 2026—2030.

(3) Twelve thousand five hundred dollars (\$12,500) for the calendar years beginning with 2031.

#019 [25 Pa. Code §§ 127.14(b) & 127.449]**Authorization for De Minimis Emission Increases**

(a) This permit authorizes de minimis emission increases from a new or existing source in accordance with 25 Pa. Code §§ 127.14 and 127.449 without the need for a plan approval or prior issuance of a permit modification. The permittee shall provide the Department with seven (7) days prior written notice before commencing any de minimis emissions increase that would result from either: (1) a physical change of minor significance under § 127.14(c)(1); or (2) the construction, installation, modification or reactivation of an air contamination source. The written notice shall:

(1) Identify and describe the pollutants that will be emitted as a result of the de minimis emissions increase.

(2) Provide emission rates expressed in tons per year and in terms necessary to establish compliance consistent with any applicable requirement.

The Department may disapprove or condition de minimis emission increases at any time.

(b) Except as provided below in (c) and (d) of this permit condition, the permittee is authorized during the term of this permit to make de minimis emission increases (expressed in tons per year) up to the following amounts without the need for a plan approval or prior issuance of a permit modification:

(1) Four tons of carbon monoxide from a single source during the term of the permit and 20 tons of carbon monoxide at the facility during the term of the permit.

(2) One ton of NO_x from a single source during the term of the permit and 5 tons of NO_x at the facility during the term of the permit.

(3) One and six-tenths tons of the oxides of sulfur from a single source during the term of the permit and 8.0 tons of oxides of sulfur at the facility during the term of the permit.

(4) Six-tenths of a ton of PM₁₀ from a single source during the term of the permit and 3.0 tons of PM₁₀ at the facility during the term of the permit. This shall include emissions of a pollutant regulated under Section 112 of the Clean Air Act unless precluded by the Clean Air Act or 25 Pa. Code Article III.

(5) One ton of VOCs from a single source during the term of the permit and 5.0 tons of VOCs at the facility during the term of the permit. This shall include emissions of a pollutant regulated under Section 112 of the Clean Air Act unless precluded by the Clean Air Act or 25 Pa. Code Article III.

(c) In accordance with § 127.14, the permittee may install the following minor sources without the need for a plan approval:

(1) Air conditioning or ventilation systems not designed to remove pollutants generated or released from other sources.

(2) Combustion units rated at 2,500,000 or less Btu per hour of heat input.

**SECTION B. General Title V Requirements**

(3) Combustion units with a rated capacity of less than 10,000,000 Btu per hour heat input fueled by natural gas supplied by a public utility, liquefied petroleum gas or by commercial fuel oils which are No. 2 or lighter, viscosity less than or equal to 5.82 c St, and which meet the sulfur content requirements of 25 Pa. Code § 123.22 (relating to combustion units). For purposes of this permit, commercial fuel oil shall be virgin oil which has no reprocessed, recycled or waste material added.

(4) Space heaters which heat by direct heat transfer.

(5) Laboratory equipment used exclusively for chemical or physical analysis.

(6) Other sources and classes of sources determined to be of minor significance by the Department.

(d) This permit does not authorize de minimis emission increases if the emissions increase would cause one or more of the following:

(1) Increase the emissions of a pollutant regulated under Section 112 of the Clean Air Act except as authorized in Subparagraphs (b)(4) and (5) of this permit condition.

(2) Subject the facility to the prevention of significant deterioration requirements in 25 Pa. Code Chapter 127, Subchapter D and/or the new source review requirements in Subchapter E.

(3) Violate any applicable requirement of the Air Pollution Control Act, the Clean Air Act, or the regulations promulgated under either of the acts.

(4) Changes which are modifications under any provision of Title I of the Clean Air Act and emission increases which would exceed the allowable emissions level (expressed as a rate of emissions or in terms of total emissions) under the Title V permit.

(e) Unless precluded by the Clean Air Act or the regulations thereunder, the permit shield described in 25 Pa. Code § 127.516 (relating to permit shield) shall extend to the changes made under 25 Pa. Code § 127.449 (relating to de minimis emission increases).

(f) Emissions authorized under this permit condition shall be included in the monitoring, recordkeeping and reporting requirements of this permit.

(g) Except for de minimis emission increases allowed under this permit, 25 Pa. Code § 127.449, or sources and physical changes meeting the requirements of 25 Pa. Code § 127.14, the permittee is prohibited from making physical changes or engaging in activities that are not specifically authorized under this permit without first applying for a plan approval. In accordance with § 127.14(b), a plan approval is not required for the construction, modification, reactivation, or installation of the sources creating the de minimis emissions increase.

(h) The permittee may not meet de minimis emission threshold levels by offsetting emission increases or decreases at the same source.

#020 [25 Pa. Code §§ 127.11a & 127.215]**Reactivation of Sources**

(a) The permittee may reactivate a source at the facility that has been out of operation or production for at least one year, but less than or equal to five (5) years, if the source is reactivated in accordance with the requirements of 25 Pa. Code §§ 127.11a and 127.215. The reactivated source will not be considered a new source.

(b) A source which has been out of operation or production for more than five (5) years but less than 10 years may be reactivated and will not be considered a new source if the permittee satisfies the conditions specified in 25 Pa. Code § 127.11a(b).

#021 [25 Pa. Code §§ 121.9 & 127.216]**Circumvention**

(a) The owner of this Title V facility, or any other person, may not circumvent the new source review requirements of 25 Pa. Code Chapter 127, Subchapter E by causing or allowing a pattern of ownership or development, including the

**SECTION B. General Title V Requirements**

phasing, staging, delaying or engaging in incremental construction, over a geographic area of a facility which, except for the pattern of ownership or development, would otherwise require a permit or submission of a plan approval application.

(b) No person may permit the use of a device, stack height which exceeds good engineering practice stack height, dispersion technique or other technique which, without resulting in reduction of the total amount of air contaminants emitted, conceals or dilutes an emission of air contaminants which would otherwise be in violation of this permit, the Air Pollution Control Act or the regulations promulgated thereunder, except that with prior approval of the Department, the device or technique may be used for control of malodors.

#022 [25 Pa. Code §§ 127.402(d) & 127.513(1)]**Submissions**

(a) Reports, test data, monitoring data, notifications and requests for renewal of the permit shall be submitted to the:

Regional Air Program Manager
PA Department of Environmental Protection
(At the address given on the permit transmittal letter, or otherwise notified)

(b) Any report or notification for the EPA Administrator or EPA Region III should be addressed to:

Enforcement & Compliance Assurance Division
Air, RCRA and Toxics Branch (3ED21)
Four Penn Center
1600 John F. Kennedy Boulevard
Philadelphia, PA 19103-2852

The Title V compliance certification shall be emailed to EPA at R3_APD_Permits@epa.gov.

(c) An application, form, report or compliance certification submitted pursuant to this permit condition shall contain certification by a responsible official as to truth, accuracy, and completeness as required under 25 Pa. Code § 127.402(d). Unless otherwise required by the Clean Air Act or regulations adopted thereunder, this certification and any other certification required pursuant to this permit shall state that, based on information and belief formed after reasonable inquiry, the statements and information in the document are true, accurate and complete.

#023 [25 Pa. Code §§ 127.441(c) & 127.463(e); Chapter 139; & 114(a)(3), 504(b) of the CAA]**Sampling, Testing and Monitoring Procedures**

(a) The permittee shall perform the emissions monitoring and analysis procedures or test methods for applicable requirements of this Title V permit. In addition to the sampling, testing and monitoring procedures specified in this permit, the Permittee shall comply with any additional applicable requirements promulgated under the Clean Air Act after permit issuance regardless of whether the permit is revised.

(b) The sampling, testing and monitoring required under the applicable requirements of this permit, shall be conducted in accordance with the requirements of 25 Pa. Code Chapter 139 unless alternative methodology is required by the Clean Air Act (including §§ 114(a)(3) and 504(b)) and regulations adopted thereunder.

#024 [25 Pa. Code §§ 127.511 & Chapter 135]**Recordkeeping Requirements**

(a) The permittee shall maintain and make available, upon request by the Department, records of required monitoring information that include the following:

- (1) The date, place (as defined in the permit) and time of sampling or measurements.
- (2) The dates the analyses were performed.
- (3) The company or entity that performed the analyses.
- (4) The analytical techniques or methods used.

**SECTION B. General Title V Requirements**

(5) The results of the analyses.

(6) The operating conditions as existing at the time of sampling or measurement.

(b) The permittee shall retain records of the required monitoring data and supporting information for at least five (5) years from the date of the monitoring sample, measurement, report or application. Supporting information includes the calibration data and maintenance records and original strip-chart recordings for continuous monitoring instrumentation, and copies of reports required by the permit.

(c) The permittee shall maintain and make available to the Department upon request, records including computerized records that may be necessary to comply with the reporting, recordkeeping and emission statement requirements in 25 Pa. Code Chapter 135 (relating to reporting of sources). In accordance with 25 Pa. Code Chapter 135, § 135.5, such records may include records of production, fuel usage, maintenance of production or pollution control equipment or other information determined by the Department to be necessary for identification and quantification of potential and actual air contaminant emissions. If direct recordkeeping is not possible or practical, sufficient records shall be kept to provide the needed information by indirect means.

#025 [25 Pa. Code §§ 127.411(d), 127.442, 127.463(e) & 127.511(c)]**Reporting Requirements**

(a) The permittee shall comply with the reporting requirements for the applicable requirements specified in this Title V permit. In addition to the reporting requirements specified herein, the permittee shall comply with any additional applicable reporting requirements promulgated under the Clean Air Act after permit issuance regardless of whether the permit is revised.

(b) Pursuant to 25 Pa. Code § 127.511(c), the permittee shall submit reports of required monitoring at least every six (6) months unless otherwise specified in this permit. Instances of deviations (as defined in 25 Pa. Code § 121.1) from permit requirements shall be clearly identified in the reports. The reporting of deviations shall include the probable cause of the deviations and corrective actions or preventative measures taken, except that sources with continuous emission monitoring systems shall report according to the protocol established and approved by the Department for the source. The required reports shall be certified by a responsible official.

(c) Every report submitted to the Department under this permit condition shall comply with the submission procedures specified in Section B, Condition #022(c) of this permit.

(d) Any records, reports or information obtained by the Department or referred to in a public hearing shall be made available to the public by the Department except for such records, reports or information for which the permittee has shown cause that the documents should be considered confidential and protected from disclosure to the public under Section 4013.2 of the Air Pollution Control Act and consistent with Sections 112(d) and 114(c) of the Clean Air Act and 25 Pa. Code § 127.411(d). The permittee may not request a claim of confidentiality for any emissions data generated for the Title V facility.

#026 [25 Pa. Code § 127.513]**Compliance Certification**

(a) One year after the date of issuance of the Title V permit, and each year thereafter, unless specified elsewhere in the permit, the permittee shall submit to the Department and EPA Region III a certificate of compliance with the terms and conditions in this permit, for the previous year, including the emission limitations, standards or work practices. This certification shall include:

- (1) The identification of each term or condition of the permit that is the basis of the certification.
- (2) The compliance status.
- (3) The methods used for determining the compliance status of the source, currently and over the reporting period.
- (4) Whether compliance was continuous or intermittent.

(b) The compliance certification shall be postmarked or hand-delivered no later than thirty days after each anniversary of the date of issuance of this Title V Operating Permit, or on the submittal date specified elsewhere in the permit, to the Department in accordance with the submission requirements specified in Section B, Condition #022 of this permit. The Title V compliance certification shall be emailed to EPA at R3_APD_Permits@epa.gov.

**SECTION B. General Title V Requirements****#027 [25 Pa. Code § 127.3]****Operational Flexibility**

The permittee is authorized to make changes within the Title V facility in accordance with the following provisions in 25 Pa. Code Chapter 127 which implement the operational flexibility requirements of Section 502(b)(10) of the Clean Air Act and Section 6.1(i) of the Air Pollution Control Act:

- (1) Section 127.14 (relating to exemptions)
- (2) Section 127.447 (relating to alternative operating scenarios)
- (3) Section 127.448 (relating to emissions trading at facilities with federally enforceable emissions caps)
- (4) Section 127.449 (relating to de minimis emission increases)
- (5) Section 127.450 (relating to administrative operating permit amendments)
- (6) Section 127.462 (relating to minor operating permit amendments)
- (7) Subchapter H (relating to general plan approvals and operating permits)

#028 [25 Pa. Code §§ 127.441(d), 127.512(i) and 40 CFR Part 68]**Risk Management**

(a) If required by Section 112(r) of the Clean Air Act, the permittee shall develop and implement an accidental release program consistent with requirements of the Clean Air Act, 40 CFR Part 68 (relating to chemical accident prevention provisions) and the Federal Chemical Safety Information, Site Security and Fuels Regulatory Relief Act (P.L. 106-40).

(b) The permittee shall prepare and implement a Risk Management Plan (RMP) which meets the requirements of Section 112(r) of the Clean Air Act, 40 CFR Part 68 and the Federal Chemical Safety Information, Site Security and Fuels Regulatory Relief Act when a regulated substance listed in 40 CFR § 68.130 is present in a process in more than the listed threshold quantity at the Title V facility. The permittee shall submit the RMP to the federal Environmental Protection Agency according to the following schedule and requirements:

- (1) The permittee shall submit the first RMP to a central point specified by EPA no later than the latest of the following:
 - (i) Three years after the date on which a regulated substance is first listed under § 68.130; or,
 - (ii) The date on which a regulated substance is first present above a threshold quantity in a process.

(2) The permittee shall submit any additional relevant information requested by the Department or EPA concerning the RMP and shall make subsequent submissions of RMPs in accordance with 40 CFR § 68.190.

(3) The permittee shall certify that the RMP is accurate and complete in accordance with the requirements of 40 CFR Part 68, including a checklist addressing the required elements of a complete RMP.

(c) As used in this permit condition, the term "process" shall be as defined in 40 CFR § 68.3. The term "process" means any activity involving a regulated substance including any use, storage, manufacturing, handling, or on-site movement of such substances or any combination of these activities. For purposes of this definition, any group of vessels that are interconnected, or separate vessels that are located such that a regulated substance could be involved in a potential release, shall be considered a single process.

(d) If the Title V facility is subject to 40 CFR Part 68, as part of the certification required under this permit, the permittee shall:

- (1) Submit a compliance schedule for satisfying the requirements of 40 CFR Part 68 by the date specified in 40 CFR § 68.10(a); or,
- (2) Certify that the Title V facility is in compliance with all requirements of 40 CFR Part 68 including the registration and submission of the RMP.

**SECTION B. General Title V Requirements**

(e) If the Title V facility is subject to 40 CFR Part 68, the permittee shall maintain records supporting the implementation of an accidental release program for five (5) years in accordance with 40 CFR § 68.200.

(f) When the Title V facility is subject to the accidental release program requirements of Section 112(r) of the Clean Air Act and 40 CFR Part 68, appropriate enforcement action will be taken by the Department if:

(1) The permittee fails to register and submit the RMP or a revised plan pursuant to 40 CFR Part 68.

(2) The permittee fails to submit a compliance schedule or include a statement in the compliance certification required under Section B, Condition #026 of this permit that the Title V facility is in compliance with the requirements of Section 112(r) of the Clean Air Act, 40 CFR Part 68, and 25 Pa. Code § 127.512(i).

#029 [25 Pa. Code § 127.512(e)]**Approved Economic Incentives and Emission Trading Programs**

No permit revision shall be required under approved economic incentives, marketable permits, emissions trading and other similar programs or processes for changes that are provided for in this Title V permit.

#030 [25 Pa. Code §§ 127.516, 127.450(d), 127.449(f) & 127.462(g)]**Permit Shield**

(a) The permittee's compliance with the conditions of this permit shall be deemed in compliance with applicable requirements (as defined in 25 Pa. Code § 121.1) as of the date of permit issuance if either of the following applies:

(1) The applicable requirements are included and are specifically identified in this permit.

(2) The Department specifically identifies in the permit other requirements that are not applicable to the permitted facility or source.

(b) Nothing in 25 Pa. Code § 127.516 or the Title V permit shall alter or affect the following:

(1) The provisions of Section 303 of the Clean Air Act, including the authority of the Administrator of the EPA provided thereunder.

(2) The liability of the permittee for a violation of an applicable requirement prior to the time of permit issuance.

(3) The applicable requirements of the acid rain program, consistent with Section 408(a) of the Clean Air Act.

(4) The ability of the EPA to obtain information from the permittee under Section 114 of the Clean Air Act.

(c) Unless precluded by the Clean Air Act or regulations thereunder, final action by the Department incorporating a significant permit modification in this Title V Permit shall be covered by the permit shield at the time that the permit containing the significant modification is issued.

#031 [25 Pa. Code §135.3]**Reporting**

(a) The permittee shall submit by March 1 of each year an annual emissions report for the preceding calendar year. The report shall include information for all active previously reported sources, new sources which were first operated during the preceding calendar year, and sources modified during the same period which were not previously reported. All air emissions from the facility should be estimated and reported.

(b) A source owner or operator may request an extension of time from the Department for the filing of an annual emissions report, and the Department may grant the extension for reasonable cause.

#032 [25 Pa. Code §135.4]**Report Format**

Emissions reports shall contain sufficient information to enable the Department to complete its emission inventory. Emissions reports shall be made by the source owner or operator in a format specified by the Department.

**SECTION C. Site Level Requirements****I. RESTRICTIONS.****Emission Restriction(s).****# 001 [25 Pa. Code §123.1]****Prohibition of certain fugitive emissions**

The permittee shall not allow the emission into the outdoor atmosphere of any fugitive air contaminant from a source other than the following:

- (a) Construction or demolition of building or structure.
- (b) Grading, paving and maintenance of roads and streets.
- (c) Use of roads and streets. Emissions from material in or on trucks, railroad cars and other vehicular equipment are not considered as emissions from use of roads and streets.
- (d) Clearing of land.
- (e) Stockpiling of material.
- (f) Sources and classes of sources other than those identified above, for which the operator has obtained a determination from the Department, in accordance with 25 Pa. Code §123.1 (b), that fugitive emissions from the source, after appropriate control, meet the following requirements:
 - (1) The emissions are of minor significance with respect to causing air pollution.
 - (2) The emissions are not preventing or interfering with the attainment or maintenance of any ambient air standard.

002 [25 Pa. Code §123.2]**Fugitive particulate matter**

The permittee shall not allow the emission of particulate matter into the outdoor atmosphere from a source specified in Condition #001 if the emissions are visible at the point the emissions pass outside the permittee's property.

003 [25 Pa. Code §123.31]**Limitations**

The permittee shall not allow the emission into the outdoor atmosphere of any malodorous air contaminants from any source in such a manner that the malodors are detectable outside the permittee's property.

004 [25 Pa. Code §123.41]**Limitations**

The permittee shall not allow the emission into the outdoor atmosphere of visible air contaminants in such a manner that the opacity of the emission is either of the following:

- (a) Equal to or greater than 20 percent for a period or periods aggregating more than three minutes in any one hour.
- (b) Equal to or greater than 60 percent at any time.

005 [25 Pa. Code §123.42]**Exceptions**

The emission limitation of 25 Pa. Code §123.41 shall not apply when:

- (a) The presence of uncombined water is the only reason for failure of the emission to meet the limitation.
- (b) The emission results from the operation of equipment used solely to train and test persons in observing the opacity of visible emissions.
- (c) The emission results from sources specified in Section C, Condition #001.

006 [25 Pa. Code §127.441]**Operating permit terms and conditions.**

The permittee shall ensure that the facility annual emissions of:

**SECTION C. Site Level Requirements**

- (a) VOC shall not exceed 160.3 tons, based on a 12-month rolling total, and
- (b) NOx shall not exceed 1,163.8 tons, based on a 12-month rolling total.

007 [25 Pa. Code §127.441]**Operating permit terms and conditions.**

(a) The permittee shall limit the facility's annual emissions to less than the following thresholds during any consecutive 12-month period:

- (1) 10 TPY of any individual hazardous air pollutant (HAP)
- (2) 25 TPY of aggregate HAPs

(b) Compliance verification requires emissions to be calculated and recorded for each month and each consecutive 12-month period.

II. TESTING REQUIREMENTS.**# 008 [25 Pa. Code §127.511]****Monitoring and related recordkeeping and reporting requirements.**

The Department reserves the right to require exhaust stack testing of sources as necessary during the permit term to verify emissions for purposes including permit condition violations, emission fees or malfunctioning.

009 [25 Pa. Code §127.512]**Operating permit terms and conditions.**

(a) Unless otherwise approved in writing by DEP, the permittee shall do the following:

(1) Conduct any performance testing in accordance with the provisions of 25 Pa Code Section 139 and the Department's Source Testing Manual and any applicable federal regulations.

(2) Submit to DEP a test protocol for review and approval at least 90 calendar days prior to commencing an emissions testing program, and not conduct the test that is the subject of the protocol until the protocol has been approved by DEP.

(3) If DEP finds deficiencies in the protocol, the permittee shall provide a response to DEP addressing the deficiencies within 30 days of being notified of the deficiencies.

(4) Complete the performance test within 90 days of DEP's approval of the test protocol, or by the due date specified elsewhere in the TV permit, whichever is later.

(b) Pursuant to 25 Pa. Code § 139.3 at least 15 calendar days prior to commencing an emission testing program, notification as to the date and time of testing shall be given to the appropriate Regional Office. Notification shall also be sent to the Division of Source Testing and Monitoring. Notification shall not be made without prior receipt of a protocol acceptance letter from the Department.

(c) Pursuant to 25 Pa. Code Section 139.53(a)(3) within 15 calendar days after completion of the on-site testing portion of an emission test program, if a complete test report has not yet been submitted, an electronic mail notification shall be sent to the Department's Division of Source Testing and Monitoring and the appropriate Regional Office indicating the completion date of the on-site testing.

(d) Pursuant to 40 CFR Part 60.8(a), 40 CFR Part 61.13(f) and 40 CFR Part 63.7(g) a complete test report shall be submitted to the Department no later than 60 calendar days after completion of the on-site testing portion of an emission test program. For those tests being conducted pursuant to 40 CFR Part 61, a complete test report shall be submitted within 31 days after completion of the test.

(e) Pursuant to 25 Pa. Code Section 139.53(b) a complete test report shall include a summary of the emission results on the first page of the report indicating if each pollutant measured is within permitted limits and a statement of compliance or non-compliance with all applicable permit conditions. The summary results will include, at a minimum, the following

**SECTION C. Site Level Requirements**

information:

- (1) A statement that the owner or operator has reviewed the report from the emissions testing body and agrees with the findings.
- (2) Permit number(s) and condition(s) which are the basis for the evaluation.
- (3) Summary of results with respect to each applicable permit condition.
- (4) Statement of compliance or non-compliance with each applicable permit condition.

(f) Pursuant to 25 Pa. Code § 139.3 to all submittals shall meet all applicable requirements specified in the most current version of the Department's Source Testing Manual.

(g) All testing shall be performed in accordance with the provisions of Chapter 139 of the Rules and Regulations of the Department of Environmental Protection.

(h) Pursuant to 25 Pa. Code Section 139.53(a)(1) and 139.53(a)(3) all submittals, besides notifications, shall be accomplished through PSIMS*Online available through <https://www.depgreenport.state.pa.us/ecomm/Login.jsp> when it becomes available. If internet submittal cannot be accomplished, submittal shall be made as follows:

Regional Office:

Digital copy (only): RA-epscstacktesting@pa.gov

Bureau of Air Quality:

Digital copy (only): RA-epstacktesting@pa.gov

(i) The permittee shall ensure all federal reporting requirements contained in the applicable subpart of 40 CFR are followed, including timelines more stringent than those contained herein. In the event of an inconsistency or any conflicting requirements between state and the federal, the most stringent provision, term, condition, method or rule shall be used by default.

III. MONITORING REQUIREMENTS.**# 010 [25 Pa. Code §123.43]****Measuring techniques**

Visible air contaminants may be measured using either of the following:

- (a) A device approved by the Department and maintained to provide accurate opacity measurement.
- (b) Observers, trained and certified in EPA Method 9 to measure plume opacity with the naked eye or with the aid of any devices approved by the Department.

011 [25 Pa. Code §127.441]**Operating permit terms and conditions.**

The permittee shall conduct a weekly inspection in accordance with the protocol in Section H, #004, around the production plant periphery where the air pollution sources are located, during daylight hours when the plant is in production to detect, visible emissions, fugitive visible emissions and odorous emissions as follows:

- (a) Visible emissions in excess of the limits stated in Section C, Condition #004.

Visible emissions may be measured according to the methods specified in Section C, Condition #010. As an alternative, plant personnel who observe such emissions may report the incidence of visible emissions to the Department within two hours of each incident and make arrangements for a certified observer to verify the visible emissions

- (b) The presence of fugitive visible emissions beyond the plant property boundaries, as stated in Section C, Condition #002.
- (c) The presence of odorous air contaminants beyond the plant property boundaries as stated in Section C, Condition #003.

**SECTION C. Site Level Requirements****# 012 [25 Pa. Code §127.511]****Monitoring and related recordkeeping and reporting requirements.**

(a) The permittee shall monitor and record the pressure drop across the Baghouse (Source ID C02, #2 Baghouse). At a minimum, these readings shall be taken once per week while the sources and control devices are in operation. These recordings shall be maintained on site for the most recent five-year period.

(b) The appropriate range of pressure drops for #2 Baghouse shall be listed by the permittee, as per the manufacturers' specification or the operational manual or the stack testing, and compared for the compliance during the facility-wide or the source inspections. The pressure drop data shall be submitted to the Department's representative upon request.

IV. RECORDKEEPING REQUIREMENTS.**# 013 [25 Pa. Code §127.441]****Operating permit terms and conditions.**

(a) The permittee shall maintain a record of each weekly inspection conducted in accordance with Section C, Condition #011. At a minimum, these records shall include the following information:

- (1) The name of the company representative conducting each inspection.
- (2) The date and time of each inspection.
- (3) The wind direction during each inspection.
- (4) A description of the emissions and/or malodors observed and the actions taken to mitigate them.

(b) The permittee shall maintain these records for a minimum of five years and shall make them available to Department representatives upon request.

V. REPORTING REQUIREMENTS.**# 014 [25 Pa. Code §127.442]****Reporting requirements.**

The permittee shall report malfunctions to the Department. A malfunction is any sudden, infrequent, and not reasonably preventable failure of air pollution control equipment, process equipment, or a process to operate in a normal or usual manner. Failures that are caused in part by poor maintenance or careless operation are not malfunctions. Malfunctions shall be reported as follows:

(a) Malfunctions which pose an imminent danger to public health, safety, welfare and the environment, shall be immediately reported to the Department by telephone. The telephone report of such malfunctions shall occur no later than two hours after discovery of the incident. Telephone reports can be made to the Southcentral Regional Office at (717) 705-4702 during normal business hours, or to the Department's Emergency Hotline at any time. The Emergency Hotline phone number is changed/updated periodically. The current Emergency Hotline phone number can be found at <https://www.dep.pa.gov/About/Regional/SouthcentralRegion/Pages/default.aspx>. The permittee shall submit a written report of instances of such malfunctions to the Department within three (3) days of the telephone report.

(b) Unless otherwise required by this permit, any other malfunction that is not subject to the reporting requirement of subsection (a) above, shall be reported to the Department, in writing, within five (5) days of malfunction discovery.

VI. WORK PRACTICE REQUIREMENTS.**# 015 [25 Pa. Code §123.1]****Prohibition of certain fugitive emissions**

The permittee shall take all reasonable actions to prevent particulate matter from a source identified in Section C, Condition #001 from becoming airborne, as per §123.1 (c). These actions shall include, but are not limited to, the following:

(a) Use, where possible, of water or chemicals for control of dust in the demolition of buildings or structures, construction operations, the grading of roads, or the clearing of land.

(b) Application of asphalt, oil, water or suitable chemicals on dirt roads, material stockpiles and other surfaces which may give rise to airborne dusts.

**SECTION C. Site Level Requirements**

(c) Paving and maintenance of roadways.

(d) Prompt removal of earth or other material from paved streets onto which earth or other material has been transported by trucking or earth moving equipment, erosion by water, or other means.

VII. ADDITIONAL REQUIREMENTS.**# 016 [25 Pa. Code §127.441]****Operating permit terms and conditions.**

The permittee shall reduce emissions of Class I and Class II refrigerants to the lowest achievable level during the service, maintenance, repair and disposal of equipment as per 40 CFR, Part 82, Subpart F, Recycling and Emission Reduction.

017 [25 Pa. Code §127.441]**Operating permit terms and conditions.**

All sources in this permit shall be operated and maintained in accordance with manufacturer's specifications, or as specified in Section B, Condition #008(b).

018 [25 Pa. Code §127.511]**Monitoring and related recordkeeping and reporting requirements.**

Pursuant to Section C, Condition #019, the permittee shall forward the annual compliance certification report to U.S. EPA electronically, in lieu of a hard copy version, to the following email address (unless otherwise specified by DEP or EPA): 'R3_APD_Permits@epa.gov'.

019 [25 Pa. Code §127.511]**Monitoring and related recordkeeping and reporting requirements.**

The permittee shall submit the following reports:

(a) An annual certificate of compliance, due by April 1st of each year, for the period covering January 1 through December 31 of the previous year.

(b) A semi-annual deviation report, due by October 1, of each year, for the period covering January 1 through June 30 of the same year. Note: The annual certification of compliance fulfills the obligation for the second deviation reporting period (July 1 through December 31 of the previous year).

020 [25 Pa. Code §129.14]**Open burning operations**

(a) No person shall conduct open burning of material at the facility, as per the §129.14(a), except where the open burning operations result from:

(1) A fire set to prevent or abate a fire hazard, when approved by the Department and set by or under the supervision of a public official.

(2) Any fire set for the purpose of instructing personnel in fire fighting, when approved by the Department.

(3) A fire set for the prevention and control of disease or pests, when approved by the Department.

(4) A fire set solely for recreational or ceremonial purposes.

(5) A fire set solely for cooking food.

(b) This permit does not constitute authorization to burn solid waste pursuant to Section 610 (3) of the Solid Waste Management Act, 35 P.S. Section 6018.610 (3), or any other provision of the Solid Waste Management Act.

VIII. COMPLIANCE CERTIFICATION.

No additional compliance certifications exist except as provided in other sections of this permit including Section B (relating to Title V General Requirements).

IX. COMPLIANCE SCHEDULE.



SECTION C. Site Level Requirements

No compliance milestones exist.

***** Permit Shield In Effect *****



SECTION D. Source Level Requirements

Source ID: 032A

Source Name: BOILER (ZURN, 14M-350)

Source Capacity/Throughput:	99.000	MMBTU/HR	
	99.000	MCF/HR	Natural Gas
	709.300	Gal/HR	#2 Oil

Conditions for this source occur in the following groups: 08
12
14

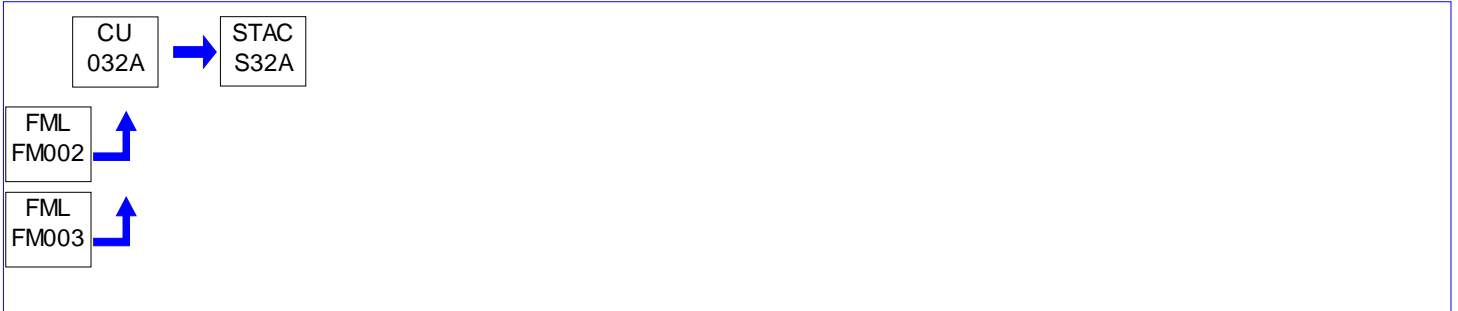

I. RESTRICTIONS.

No additional requirements exist except as provided in other sections of this permit including Section B (Title V General Requirements) and/or Section E (Source Group Restrictions).

II. TESTING REQUIREMENTS.

No additional testing requirements exist except as provided in other sections of this permit including Section B (Title V General Requirements) and/or Section E (Source Group Restrictions).

III. MONITORING REQUIREMENTS.

No additional monitoring requirements exist except as provided in other sections of this permit including Section B (Title V General Requirements) and/or Section E (Source Group Restrictions).

IV. RECORDKEEPING REQUIREMENTS.

No additional record keeping requirements exist except as provided in other sections of this permit including Section B (Title V General Requirements) and/or Section E (Source Group Restrictions).

V. REPORTING REQUIREMENTS.

No additional reporting requirements exist except as provided in other sections of this permit including Section B (Title V General Requirements) and/or Section E (Source Group Restrictions).

VI. WORK PRACTICE REQUIREMENTS.

No additional work practice requirements exist except as provided in other sections of this permit including Section B (Title V General Requirements) and/or Section E (Source Group Restrictions).

VII. ADDITIONAL REQUIREMENTS.

No additional requirements exist except as provided in other sections of this permit including Section B (Title V General Requirements) and/or Section E (Source Group Restrictions).



SECTION D. Source Level Requirements

***** Permit Shield in Effect. *****



SECTION D. Source Level Requirements

***** Permit Shield in Effect. *****

**SECTION D. Source Level Requirements**

Source ID: 033

Source Name: PLANT HOT WATER HEATERS

Source Capacity/Throughput:

9.900 MCF/HR

Natural Gas

Conditions for this source occur in the following groups: 05
13

**I. RESTRICTIONS.**

No additional requirements exist except as provided in other sections of this permit including Section B (Title V General Requirements) and/or Section E (Source Group Restrictions).

II. TESTING REQUIREMENTS.

No additional testing requirements exist except as provided in other sections of this permit including Section B (Title V General Requirements) and/or Section E (Source Group Restrictions).

III. MONITORING REQUIREMENTS.

No additional monitoring requirements exist except as provided in other sections of this permit including Section B (Title V General Requirements) and/or Section E (Source Group Restrictions).

IV. RECORDKEEPING REQUIREMENTS.

No additional record keeping requirements exist except as provided in other sections of this permit including Section B (Title V General Requirements) and/or Section E (Source Group Restrictions).

V. REPORTING REQUIREMENTS.

No additional reporting requirements exist except as provided in other sections of this permit including Section B (Title V General Requirements) and/or Section E (Source Group Restrictions).

VI. WORK PRACTICE REQUIREMENTS.

No additional work practice requirements exist except as provided in other sections of this permit including Section B (Title V General Requirements) and/or Section E (Source Group Restrictions).

VII. ADDITIONAL REQUIREMENTS.

No additional requirements exist except as provided in other sections of this permit including Section B (Title V General Requirements) and/or Section E (Source Group Restrictions).

***** Permit Shield in Effect. *****



SECTION D. Source Level Requirements

Source ID: 034

Source Name: SHOP SPACE HEATERS

Source Capacity/Throughput:

30.000 MCF/HR

Natural Gas

Conditions for this source occur in the following groups: 05
13

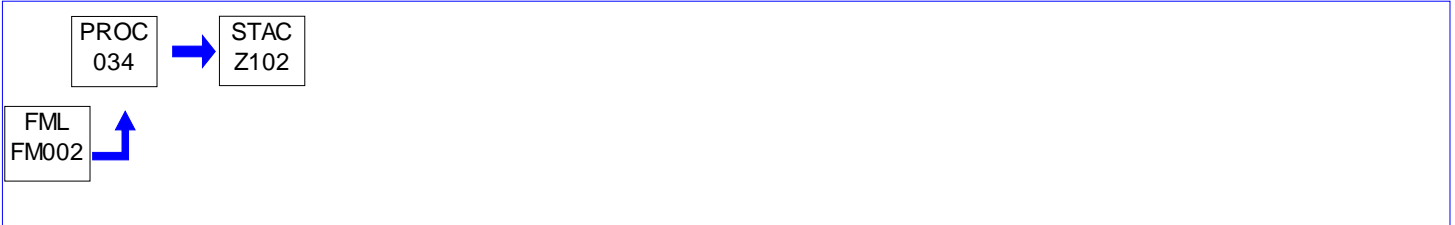

I. RESTRICTIONS.

No additional requirements exist except as provided in other sections of this permit including Section B (Title V General Requirements) and/or Section E (Source Group Restrictions).

II. TESTING REQUIREMENTS.

No additional testing requirements exist except as provided in other sections of this permit including Section B (Title V General Requirements) and/or Section E (Source Group Restrictions).

III. MONITORING REQUIREMENTS.

No additional monitoring requirements exist except as provided in other sections of this permit including Section B (Title V General Requirements) and/or Section E (Source Group Restrictions).

IV. RECORDKEEPING REQUIREMENTS.

No additional record keeping requirements exist except as provided in other sections of this permit including Section B (Title V General Requirements) and/or Section E (Source Group Restrictions).

V. REPORTING REQUIREMENTS.

No additional reporting requirements exist except as provided in other sections of this permit including Section B (Title V General Requirements) and/or Section E (Source Group Restrictions).

VI. WORK PRACTICE REQUIREMENTS.

No additional work practice requirements exist except as provided in other sections of this permit including Section B (Title V General Requirements) and/or Section E (Source Group Restrictions).

VII. ADDITIONAL REQUIREMENTS.

No additional requirements exist except as provided in other sections of this permit including Section B (Title V General Requirements) and/or Section E (Source Group Restrictions).

***** Permit Shield in Effect. *****



SECTION D. Source Level Requirements

Source ID: 102

Source Name: CONTROLLED COOLING BOXES 1 - 8

Source Capacity/Throughput:	250.000 Tons/HR	STEEL RAILS
	4.600 MCF/HR	NATURAL GAS

Conditions for this source occur in the following groups: 04
13

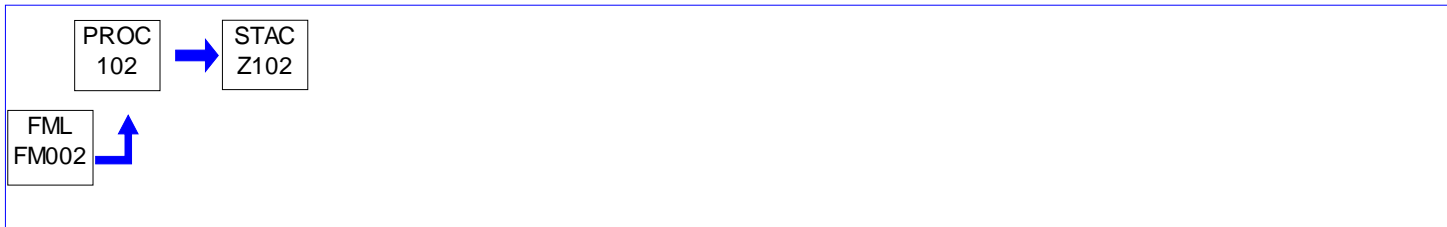

I. RESTRICTIONS.

No additional requirements exist except as provided in other sections of this permit including Section B (Title V General Requirements) and/or Section E (Source Group Restrictions).

II. TESTING REQUIREMENTS.

No additional testing requirements exist except as provided in other sections of this permit including Section B (Title V General Requirements) and/or Section E (Source Group Restrictions).

III. MONITORING REQUIREMENTS.

No additional monitoring requirements exist except as provided in other sections of this permit including Section B (Title V General Requirements) and/or Section E (Source Group Restrictions).

IV. RECORDKEEPING REQUIREMENTS.

No additional record keeping requirements exist except as provided in other sections of this permit including Section B (Title V General Requirements) and/or Section E (Source Group Restrictions).

V. REPORTING REQUIREMENTS.

No additional reporting requirements exist except as provided in other sections of this permit including Section B (Title V General Requirements) and/or Section E (Source Group Restrictions).

VI. WORK PRACTICE REQUIREMENTS.

No additional work practice requirements exist except as provided in other sections of this permit including Section B (Title V General Requirements) and/or Section E (Source Group Restrictions).

VII. ADDITIONAL REQUIREMENTS.

No additional requirements exist except as provided in other sections of this permit including Section B (Title V General Requirements) and/or Section E (Source Group Restrictions).

***** Permit Shield in Effect. *****

**SECTION D. Source Level Requirements**

Source ID: 109

Source Name: EAF LADLE PREHEATERS 1-4

Source Capacity/Throughput:

9.600 MCF/HR

NATURAL GAS

Conditions for this source occur in the following groups: 04

13

14

**I. RESTRICTIONS.**

No additional requirements exist except as provided in other sections of this permit including Section B (Title V General Requirements) and/or Section E (Source Group Restrictions).

II. TESTING REQUIREMENTS.

No additional testing requirements exist except as provided in other sections of this permit including Section B (Title V General Requirements) and/or Section E (Source Group Restrictions).

III. MONITORING REQUIREMENTS.

No additional monitoring requirements exist except as provided in other sections of this permit including Section B (Title V General Requirements) and/or Section E (Source Group Restrictions).

IV. RECORDKEEPING REQUIREMENTS.

No additional record keeping requirements exist except as provided in other sections of this permit including Section B (Title V General Requirements) and/or Section E (Source Group Restrictions).

V. REPORTING REQUIREMENTS.

No additional reporting requirements exist except as provided in other sections of this permit including Section B (Title V General Requirements) and/or Section E (Source Group Restrictions).

VI. WORK PRACTICE REQUIREMENTS.

No additional work practice requirements exist except as provided in other sections of this permit including Section B (Title V General Requirements) and/or Section E (Source Group Restrictions).

VII. ADDITIONAL REQUIREMENTS.

No additional requirements exist except as provided in other sections of this permit including Section B (Title V General Requirements) and/or Section E (Source Group Restrictions).

*** Permit Shield in Effect. ***

**SECTION D. Source Level Requirements**

Source ID: 113

Source Name: BURN OFF OVEN

Source Capacity/Throughput:

0.500 MCF/HR

Natural Gas

Conditions for this source occur in the following groups: 13

**I. RESTRICTIONS.**

No additional requirements exist except as provided in other sections of this permit including Section B (Title V General Requirements) and/or Section E (Source Group Restrictions).

II. TESTING REQUIREMENTS.

No additional testing requirements exist except as provided in other sections of this permit including Section B (Title V General Requirements) and/or Section E (Source Group Restrictions).

III. MONITORING REQUIREMENTS.

No additional monitoring requirements exist except as provided in other sections of this permit including Section B (Title V General Requirements) and/or Section E (Source Group Restrictions).

IV. RECORDKEEPING REQUIREMENTS.

No additional record keeping requirements exist except as provided in other sections of this permit including Section B (Title V General Requirements) and/or Section E (Source Group Restrictions).

V. REPORTING REQUIREMENTS.

No additional reporting requirements exist except as provided in other sections of this permit including Section B (Title V General Requirements) and/or Section E (Source Group Restrictions).

VI. WORK PRACTICE REQUIREMENTS.

001 [25 Pa. Code §127.444]

Compliance requirements.

The Burn Off Oven shall be operated on commercial natural gas or propane.

VII. ADDITIONAL REQUIREMENTS.

No additional requirements exist except as provided in other sections of this permit including Section B (Title V General Requirements) and/or Section E (Source Group Restrictions).

***** Permit Shield in Effect. *****

**SECTION D. Source Level Requirements**

Source ID: 114

Source Name: CONTIN. CASTER TUNDISH PREHTR. 1 & 2

Source Capacity/Throughput:

19.900 MCF/HR

Natural Gas

Conditions for this source occur in the following groups: 04

13

14

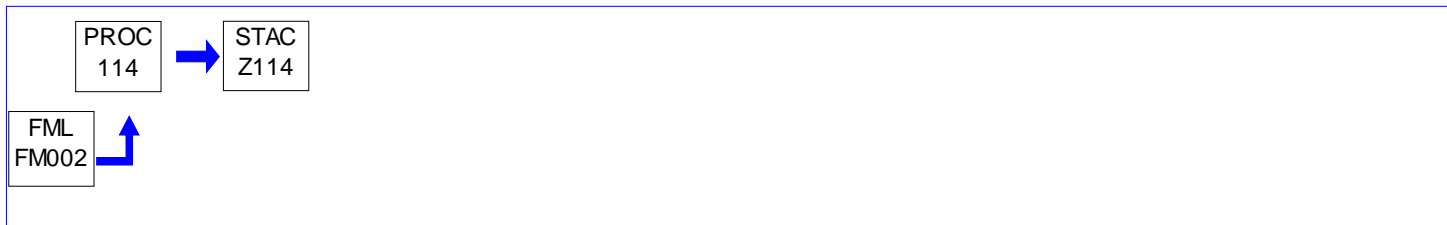
**I. RESTRICTIONS.**

No additional requirements exist except as provided in other sections of this permit including Section B (Title V General Requirements) and/or Section E (Source Group Restrictions).

II. TESTING REQUIREMENTS.

No additional testing requirements exist except as provided in other sections of this permit including Section B (Title V General Requirements) and/or Section E (Source Group Restrictions).

III. MONITORING REQUIREMENTS.

No additional monitoring requirements exist except as provided in other sections of this permit including Section B (Title V General Requirements) and/or Section E (Source Group Restrictions).

IV. RECORDKEEPING REQUIREMENTS.

No additional record keeping requirements exist except as provided in other sections of this permit including Section B (Title V General Requirements) and/or Section E (Source Group Restrictions).

V. REPORTING REQUIREMENTS.

No additional reporting requirements exist except as provided in other sections of this permit including Section B (Title V General Requirements) and/or Section E (Source Group Restrictions).

VI. WORK PRACTICE REQUIREMENTS.

No additional work practice requirements exist except as provided in other sections of this permit including Section B (Title V General Requirements) and/or Section E (Source Group Restrictions).

VII. ADDITIONAL REQUIREMENTS.

No additional requirements exist except as provided in other sections of this permit including Section B (Title V General Requirements) and/or Section E (Source Group Restrictions).

***** Permit Shield in Effect. *****

**SECTION D. Source Level Requirements**

Source ID: 116

Source Name: CONTINUOUS CASTER TUNDISH DRYER 1

Source Capacity/Throughput: 4.600 MCF/HR Natural Gas

Conditions for this source occur in the following groups: 04
13
14

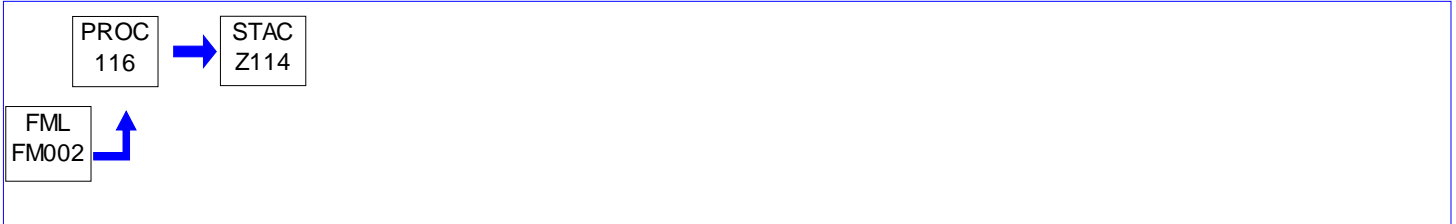
**I. RESTRICTIONS.**

No additional requirements exist except as provided in other sections of this permit including Section B (Title V General Requirements) and/or Section E (Source Group Restrictions).

II. TESTING REQUIREMENTS.

No additional testing requirements exist except as provided in other sections of this permit including Section B (Title V General Requirements) and/or Section E (Source Group Restrictions).

III. MONITORING REQUIREMENTS.

No additional monitoring requirements exist except as provided in other sections of this permit including Section B (Title V General Requirements) and/or Section E (Source Group Restrictions).

IV. RECORDKEEPING REQUIREMENTS.

No additional record keeping requirements exist except as provided in other sections of this permit including Section B (Title V General Requirements) and/or Section E (Source Group Restrictions).

V. REPORTING REQUIREMENTS.

No additional reporting requirements exist except as provided in other sections of this permit including Section B (Title V General Requirements) and/or Section E (Source Group Restrictions).

VI. WORK PRACTICE REQUIREMENTS.

No additional work practice requirements exist except as provided in other sections of this permit including Section B (Title V General Requirements) and/or Section E (Source Group Restrictions).

VII. ADDITIONAL REQUIREMENTS.

No additional requirements exist except as provided in other sections of this permit including Section B (Title V General Requirements) and/or Section E (Source Group Restrictions).

***** Permit Shield in Effect. *****

**SECTION D. Source Level Requirements**

Source ID: 118

Source Name: CASTER CUTTING TORCHES 1-6

Source Capacity/Throughput:

4.600 MCF/HR

NATURAL GAS

Conditions for this source occur in the following groups: 05
13

**I. RESTRICTIONS.**

No additional requirements exist except as provided in other sections of this permit including Section B (Title V General Requirements) and/or Section E (Source Group Restrictions).

II. TESTING REQUIREMENTS.

No additional testing requirements exist except as provided in other sections of this permit including Section B (Title V General Requirements) and/or Section E (Source Group Restrictions).

III. MONITORING REQUIREMENTS.

No additional monitoring requirements exist except as provided in other sections of this permit including Section B (Title V General Requirements) and/or Section E (Source Group Restrictions).

IV. RECORDKEEPING REQUIREMENTS.

No additional record keeping requirements exist except as provided in other sections of this permit including Section B (Title V General Requirements) and/or Section E (Source Group Restrictions).

V. REPORTING REQUIREMENTS.

No additional reporting requirements exist except as provided in other sections of this permit including Section B (Title V General Requirements) and/or Section E (Source Group Restrictions).

VI. WORK PRACTICE REQUIREMENTS.

No additional work practice requirements exist except as provided in other sections of this permit including Section B (Title V General Requirements) and/or Section E (Source Group Restrictions).

VII. ADDITIONAL REQUIREMENTS.

No additional requirements exist except as provided in other sections of this permit including Section B (Title V General Requirements) and/or Section E (Source Group Restrictions).

***** Permit Shield in Effect. *****

**SECTION D. Source Level Requirements**

Source ID: 124

Source Name: CASTER VENTS

Source Capacity/Throughput: 250.000 Tons/HR STEEL

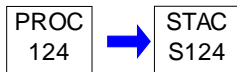
Conditions for this source occur in the following groups: 13
15**I. RESTRICTIONS.**

No additional requirements exist except as provided in other sections of this permit including Section B (Title V General Requirements) and/or Section E (Source Group Restrictions).

II. TESTING REQUIREMENTS.

No additional testing requirements exist except as provided in other sections of this permit including Section B (Title V General Requirements) and/or Section E (Source Group Restrictions).

III. MONITORING REQUIREMENTS.

No additional monitoring requirements exist except as provided in other sections of this permit including Section B (Title V General Requirements) and/or Section E (Source Group Restrictions).

IV. RECORDKEEPING REQUIREMENTS.

No additional record keeping requirements exist except as provided in other sections of this permit including Section B (Title V General Requirements) and/or Section E (Source Group Restrictions).

V. REPORTING REQUIREMENTS.

No additional reporting requirements exist except as provided in other sections of this permit including Section B (Title V General Requirements) and/or Section E (Source Group Restrictions).

VI. WORK PRACTICE REQUIREMENTS.

No additional work practice requirements exist except as provided in other sections of this permit including Section B (Title V General Requirements) and/or Section E (Source Group Restrictions).

VII. ADDITIONAL REQUIREMENTS.

No additional requirements exist except as provided in other sections of this permit including Section B (Title V General Requirements) and/or Section E (Source Group Restrictions).

***** Permit Shield in Effect. *****

**SECTION D. Source Level Requirements**

Source ID: 129

Source Name: RAILROAD CAR INGOT HEATERS

Source Capacity/Throughput:

17.900 MCF/HR

Natural Gas

Conditions for this source occur in the following groups: 05

14

**I. RESTRICTIONS.**

No additional requirements exist except as provided in other sections of this permit including Section B (Title V General Requirements) and/or Section E (Source Group Restrictions).

II. TESTING REQUIREMENTS.

No additional testing requirements exist except as provided in other sections of this permit including Section B (Title V General Requirements) and/or Section E (Source Group Restrictions).

III. MONITORING REQUIREMENTS.

No additional monitoring requirements exist except as provided in other sections of this permit including Section B (Title V General Requirements) and/or Section E (Source Group Restrictions).

IV. RECORDKEEPING REQUIREMENTS.

No additional record keeping requirements exist except as provided in other sections of this permit including Section B (Title V General Requirements) and/or Section E (Source Group Restrictions).

V. REPORTING REQUIREMENTS.

No additional reporting requirements exist except as provided in other sections of this permit including Section B (Title V General Requirements) and/or Section E (Source Group Restrictions).

VI. WORK PRACTICE REQUIREMENTS.

No additional work practice requirements exist except as provided in other sections of this permit including Section B (Title V General Requirements) and/or Section E (Source Group Restrictions).

VII. ADDITIONAL REQUIREMENTS.

No additional requirements exist except as provided in other sections of this permit including Section B (Title V General Requirements) and/or Section E (Source Group Restrictions).

***** Permit Shield in Effect. *****

**SECTION D. Source Level Requirements**

Source ID: 130

Source Name: INGOT TEEMING

Source Capacity/Throughput: 150.000 Tons/HR STEEL

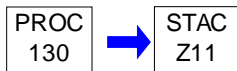
**I. RESTRICTIONS.**

No additional requirements exist except as provided in other sections of this permit including Section B (Title V General Requirements).

II. TESTING REQUIREMENTS.

No additional testing requirements exist except as provided in other sections of this permit including Section B (Title V General Requirements).

III. MONITORING REQUIREMENTS.

No additional monitoring requirements exist except as provided in other sections of this permit including Section B (Title V General Requirements).

IV. RECORDKEEPING REQUIREMENTS.

No additional record keeping requirements exist except as provided in other sections of this permit including Section B (Title V General Requirements).

V. REPORTING REQUIREMENTS.

No additional reporting requirements exist except as provided in other sections of this permit including Section B (Title V General Requirements).

VI. WORK PRACTICE REQUIREMENTS.

No additional work practice requirements exist except as provided in other sections of this permit including Section B (Title V General Requirements).

VII. ADDITIONAL REQUIREMENTS.

No additional requirements exist except as provided in other sections of this permit including Section B (Title V General Requirements).

***** Permit Shield in Effect. *****

**SECTION D. Source Level Requirements**

Source ID: 131

Source Name: VACUUM DEGASSER AT INGOT TEEMING

Source Capacity/Throughput: 150.000 Tons/HR STEEL

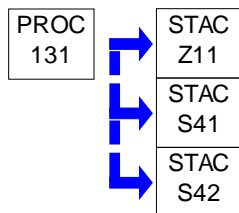
**I. RESTRICTIONS.**

No additional requirements exist except as provided in other sections of this permit including Section B (Title V General Requirements).

II. TESTING REQUIREMENTS.

No additional testing requirements exist except as provided in other sections of this permit including Section B (Title V General Requirements).

III. MONITORING REQUIREMENTS.

No additional monitoring requirements exist except as provided in other sections of this permit including Section B (Title V General Requirements).

IV. RECORDKEEPING REQUIREMENTS.

No additional record keeping requirements exist except as provided in other sections of this permit including Section B (Title V General Requirements).

V. REPORTING REQUIREMENTS.

No additional reporting requirements exist except as provided in other sections of this permit including Section B (Title V General Requirements).

VI. WORK PRACTICE REQUIREMENTS.

No additional work practice requirements exist except as provided in other sections of this permit including Section B (Title V General Requirements).

VII. ADDITIONAL REQUIREMENTS.

No additional requirements exist except as provided in other sections of this permit including Section B (Title V General Requirements).

***** Permit Shield in Effect. *****

**SECTION D. Source Level Requirements**

Source ID: 132A

Source Name: 44" MILL HOT ROLLING OPERATIONS

Source Capacity/Throughput: 250.000 Tons/HR STEEL

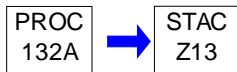
Conditions for this source occur in the following groups: 02
15**I. RESTRICTIONS.**

No additional requirements exist except as provided in other sections of this permit including Section B (Title V General Requirements) and/or Section E (Source Group Restrictions).

II. TESTING REQUIREMENTS.

No additional testing requirements exist except as provided in other sections of this permit including Section B (Title V General Requirements) and/or Section E (Source Group Restrictions).

III. MONITORING REQUIREMENTS.

No additional monitoring requirements exist except as provided in other sections of this permit including Section B (Title V General Requirements) and/or Section E (Source Group Restrictions).

IV. RECORDKEEPING REQUIREMENTS.

No additional record keeping requirements exist except as provided in other sections of this permit including Section B (Title V General Requirements) and/or Section E (Source Group Restrictions).

V. REPORTING REQUIREMENTS.

No additional reporting requirements exist except as provided in other sections of this permit including Section B (Title V General Requirements) and/or Section E (Source Group Restrictions).

VI. WORK PRACTICE REQUIREMENTS.

No additional work practice requirements exist except as provided in other sections of this permit including Section B (Title V General Requirements) and/or Section E (Source Group Restrictions).

VII. ADDITIONAL REQUIREMENTS.

No additional requirements exist except as provided in other sections of this permit including Section B (Title V General Requirements) and/or Section E (Source Group Restrictions).

***** Permit Shield in Effect. *****

**SECTION D. Source Level Requirements**

Source ID: 132B

Source Name: 28"/35" MILL HOT ROLLING OPERATIONS

Source Capacity/Throughput: 250.000 Tons/HR STEEL

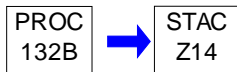
Conditions for this source occur in the following groups: 02
15**I. RESTRICTIONS.**

No additional requirements exist except as provided in other sections of this permit including Section B (Title V General Requirements) and/or Section E (Source Group Restrictions).

II. TESTING REQUIREMENTS.

No additional testing requirements exist except as provided in other sections of this permit including Section B (Title V General Requirements) and/or Section E (Source Group Restrictions).

III. MONITORING REQUIREMENTS.

No additional monitoring requirements exist except as provided in other sections of this permit including Section B (Title V General Requirements) and/or Section E (Source Group Restrictions).

IV. RECORDKEEPING REQUIREMENTS.

No additional record keeping requirements exist except as provided in other sections of this permit including Section B (Title V General Requirements) and/or Section E (Source Group Restrictions).

V. REPORTING REQUIREMENTS.

No additional reporting requirements exist except as provided in other sections of this permit including Section B (Title V General Requirements) and/or Section E (Source Group Restrictions).

VI. WORK PRACTICE REQUIREMENTS.

No additional work practice requirements exist except as provided in other sections of this permit including Section B (Title V General Requirements) and/or Section E (Source Group Restrictions).

VII. ADDITIONAL REQUIREMENTS.

No additional requirements exist except as provided in other sections of this permit including Section B (Title V General Requirements) and/or Section E (Source Group Restrictions).

***** Permit Shield in Effect. *****

**SECTION D. Source Level Requirements**

Source ID: 132C

Source Name: 20" MILL HOT ROLLING OPERATIONS

Source Capacity/Throughput: 250.000 Tons/HR STEEL

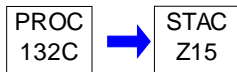
Conditions for this source occur in the following groups: 02
15**I. RESTRICTIONS.**

No additional requirements exist except as provided in other sections of this permit including Section B (Title V General Requirements) and/or Section E (Source Group Restrictions).

II. TESTING REQUIREMENTS.

No additional testing requirements exist except as provided in other sections of this permit including Section B (Title V General Requirements) and/or Section E (Source Group Restrictions).

III. MONITORING REQUIREMENTS.

No additional monitoring requirements exist except as provided in other sections of this permit including Section B (Title V General Requirements) and/or Section E (Source Group Restrictions).

IV. RECORDKEEPING REQUIREMENTS.

No additional record keeping requirements exist except as provided in other sections of this permit including Section B (Title V General Requirements) and/or Section E (Source Group Restrictions).

V. REPORTING REQUIREMENTS.

No additional reporting requirements exist except as provided in other sections of this permit including Section B (Title V General Requirements) and/or Section E (Source Group Restrictions).

VI. WORK PRACTICE REQUIREMENTS.

No additional work practice requirements exist except as provided in other sections of this permit including Section B (Title V General Requirements) and/or Section E (Source Group Restrictions).

VII. ADDITIONAL REQUIREMENTS.

No additional requirements exist except as provided in other sections of this permit including Section B (Title V General Requirements) and/or Section E (Source Group Restrictions).

***** Permit Shield in Effect. *****

**SECTION D. Source Level Requirements**

Source ID: 137

Source Name: RAIL STENCILING

Source Capacity/Throughput:

2.000 Lbs/HR

INK

Conditions for this source occur in the following groups: 14

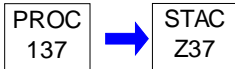
**I. RESTRICTIONS.****Emission Restriction(s).**

001 [25 Pa. Code §127.441]

Operating permit terms and conditions.

Annual VOC emissions from Rail Stenciling shall not exceed 2.7 tpy, based on a 12-month rolling total.

II. TESTING REQUIREMENTS.

No additional testing requirements exist except as provided in other sections of this permit including Section B (Title V General Requirements) and/or Section E (Source Group Restrictions).

III. MONITORING REQUIREMENTS.

No additional monitoring requirements exist except as provided in other sections of this permit including Section B (Title V General Requirements) and/or Section E (Source Group Restrictions).

IV. RECORDKEEPING REQUIREMENTS.

002 [25 Pa. Code §127.441]

Operating permit terms and conditions.

The permittee shall keep a monthly record of rail ink usage, and the VOC emissions, to demonstrate compliance with Condition #001, above.

V. REPORTING REQUIREMENTS.

No additional reporting requirements exist except as provided in other sections of this permit including Section B (Title V General Requirements) and/or Section E (Source Group Restrictions).

VI. WORK PRACTICE REQUIREMENTS.

No additional work practice requirements exist except as provided in other sections of this permit including Section B (Title V General Requirements) and/or Section E (Source Group Restrictions).

VII. ADDITIONAL REQUIREMENTS.

No additional requirements exist except as provided in other sections of this permit including Section B (Title V General Requirements) and/or Section E (Source Group Restrictions).

***** Permit Shield in Effect. *****

**SECTION D. Source Level Requirements**

Source ID: 138

Source Name: SCRAP PREPARATION

Source Capacity/Throughput:	31.300 Tons/HR	SCRAP STEEL
	11.200 MCF/HR	NATURAL GAS

Conditions for this source occur in the following groups: 05
14

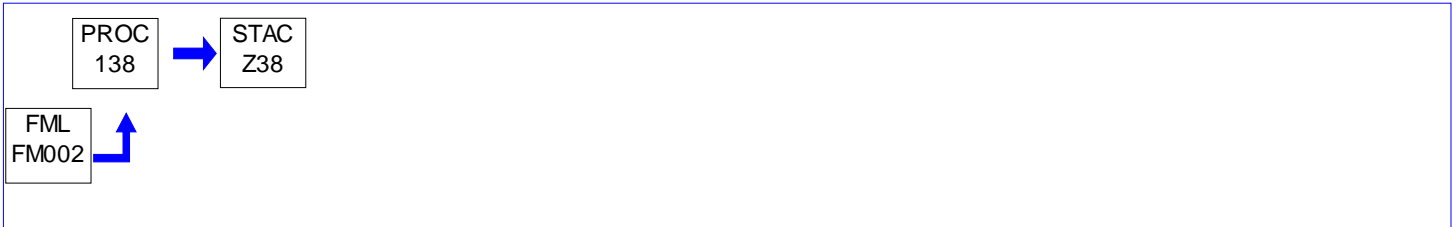
**I. RESTRICTIONS.**

No additional requirements exist except as provided in other sections of this permit including Section B (Title V General Requirements) and/or Section E (Source Group Restrictions).

II. TESTING REQUIREMENTS.

No additional testing requirements exist except as provided in other sections of this permit including Section B (Title V General Requirements) and/or Section E (Source Group Restrictions).

III. MONITORING REQUIREMENTS.

No additional monitoring requirements exist except as provided in other sections of this permit including Section B (Title V General Requirements) and/or Section E (Source Group Restrictions).

IV. RECORDKEEPING REQUIREMENTS.

No additional record keeping requirements exist except as provided in other sections of this permit including Section B (Title V General Requirements) and/or Section E (Source Group Restrictions).

V. REPORTING REQUIREMENTS.

No additional reporting requirements exist except as provided in other sections of this permit including Section B (Title V General Requirements) and/or Section E (Source Group Restrictions).

VI. WORK PRACTICE REQUIREMENTS.

No additional work practice requirements exist except as provided in other sections of this permit including Section B (Title V General Requirements) and/or Section E (Source Group Restrictions).

VII. ADDITIONAL REQUIREMENTS.

No additional requirements exist except as provided in other sections of this permit including Section B (Title V General Requirements) and/or Section E (Source Group Restrictions).

***** Permit Shield in Effect. *****

**SECTION D. Source Level Requirements**

Source ID: 140

Source Name: MOTOR VEHICLE FUELING

Source Capacity/Throughput:

Conditions for this source occur in the following groups: 17

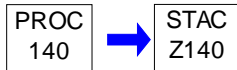
**I. RESTRICTIONS.**

No additional requirements exist except as provided in other sections of this permit including Section B (Title V General Requirements) and/or Section E (Source Group Restrictions).

II. TESTING REQUIREMENTS.

No additional testing requirements exist except as provided in other sections of this permit including Section B (Title V General Requirements) and/or Section E (Source Group Restrictions).

III. MONITORING REQUIREMENTS.

No additional monitoring requirements exist except as provided in other sections of this permit including Section B (Title V General Requirements) and/or Section E (Source Group Restrictions).

IV. RECORDKEEPING REQUIREMENTS.

No additional record keeping requirements exist except as provided in other sections of this permit including Section B (Title V General Requirements) and/or Section E (Source Group Restrictions).

V. REPORTING REQUIREMENTS.

No additional reporting requirements exist except as provided in other sections of this permit including Section B (Title V General Requirements) and/or Section E (Source Group Restrictions).

VI. WORK PRACTICE REQUIREMENTS.

No additional work practice requirements exist except as provided in other sections of this permit including Section B (Title V General Requirements) and/or Section E (Source Group Restrictions).

VII. ADDITIONAL REQUIREMENTS.

No additional requirements exist except as provided in other sections of this permit including Section B (Title V General Requirements) and/or Section E (Source Group Restrictions).

***** Permit Shield in Effect. *****

**SECTION D. Source Level Requirements**

Source ID: 232C

Source Name: 20" MILL REHEAT FURNACE

Source Capacity/Throughput:	250.000 Tons/HR	STEEL
	180.000 MCF/HR	NATURAL GAS

Conditions for this source occur in the following groups: 03
13
15

**I. RESTRICTIONS.****Emission Restriction(s).****# 001 [25 Pa. Code §127.441]****Operating permit terms and conditions.**

(a) The permittee shall limit annual NO_x emissions from Source ID 232C to 99.9 tons based on any consecutive 12-month period.

(b) Compliance verification requires emissions to be calculated and recorded for each month and each consecutive 12-month period.

II. TESTING REQUIREMENTS.

No additional testing requirements exist except as provided in other sections of this permit including Section B (Title V General Requirements) and/or Section E (Source Group Restrictions).

III. MONITORING REQUIREMENTS.

No additional monitoring requirements exist except as provided in other sections of this permit including Section B (Title V General Requirements) and/or Section E (Source Group Restrictions).

IV. RECORDKEEPING REQUIREMENTS.

No additional record keeping requirements exist except as provided in other sections of this permit including Section B (Title V General Requirements) and/or Section E (Source Group Restrictions).

V. REPORTING REQUIREMENTS.

No additional reporting requirements exist except as provided in other sections of this permit including Section B (Title V General Requirements) and/or Section E (Source Group Restrictions).

VI. WORK PRACTICE REQUIREMENTS.

No additional work practice requirements exist except as provided in other sections of this permit including Section B (Title V General Requirements) and/or Section E (Source Group Restrictions).

**SECTION D. Source Level Requirements****VII. ADDITIONAL REQUIREMENTS.**

No additional requirements exist except as provided in other sections of this permit including Section B (Title V General Requirements) and/or Section E (Source Group Restrictions).

***** Permit Shield in Effect. *****

**SECTION D. Source Level Requirements**

Source ID: 301

Source Name: 35" MILL REHEAT FURNACES 3 & 4

Source Capacity/Throughput:	116.000 Tons/HR	STEEL
	80.000 MCF/HR	NATURAL GAS

Conditions for this source occur in the following groups: 13
15

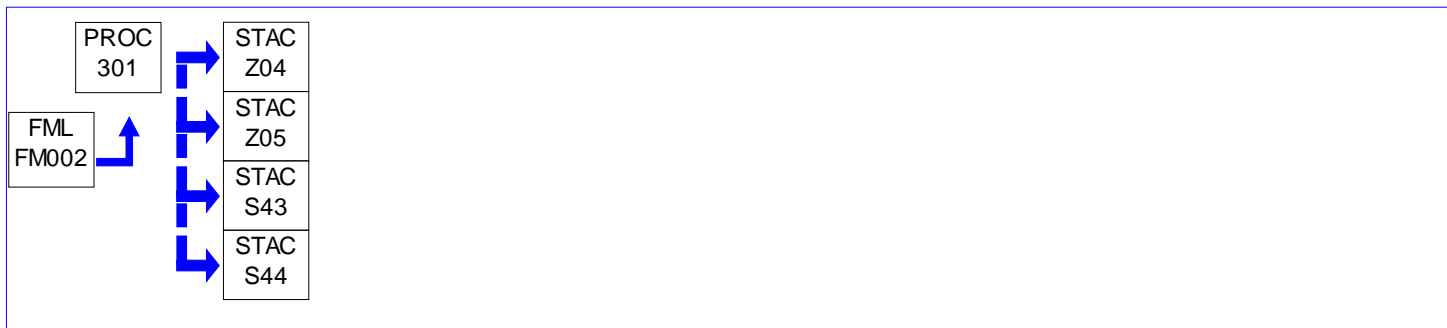
**I. RESTRICTIONS.****Emission Restriction(s).****# 001 [25 Pa. Code §123.13]****Processes**

No person shall permit the emission into the outdoor atmosphere of particulate matter from Source ID. 301 in a manner that the concentration of particulate matter in the effluent gas exceeds 0.04 grain per dry standard cubic foot.

002 [25 Pa. Code §123.21]**General**

No person shall permit the emission into the outdoor atmosphere of sulfur dioxide from the Source ID. 301 in a manner that the concentration of sulfur oxides, expressed as SO₂, in the effluent gas exceeds 500 parts per million, by volume, dry basis.

003 [25 Pa. Code §127.441]**Operating permit terms and conditions.**

(a) The permittee shall limit annual NO_x emissions from each reheat furnace under Source ID 301 to 99.9 tons based on any consecutive 12-month period.

(b) Compliance verification requires emissions to be calculated and recorded for each reheat furnace monthly and each consecutive 12-month period.

II. TESTING REQUIREMENTS.

No additional testing requirements exist except as provided in other sections of this permit including Section B (Title V General Requirements) and/or Section E (Source Group Restrictions).

III. MONITORING REQUIREMENTS.

No additional monitoring requirements exist except as provided in other sections of this permit including Section B (Title V General Requirements) and/or Section E (Source Group Restrictions).

IV. RECORDKEEPING REQUIREMENTS.**# 004 [25 Pa. Code §127.441]****Operating permit terms and conditions.**

(a) For Source ID. 301, the permittee shall keep records of monthly usage including throughput tonnage of steel, fuel (heat input), NO_x and VOC emissions.



SECTION D. Source Level Requirements

(b) The AP-42 emissions factors or stack test emission factors may be used to verify and correlate the steel through put, monthly emissions and compliance.

V. REPORTING REQUIREMENTS.

No additional reporting requirements exist except as provided in other sections of this permit including Section B (Title V General Requirements) and/or Section E (Source Group Restrictions).

VI. WORK PRACTICE REQUIREMENTS.

No additional work practice requirements exist except as provided in other sections of this permit including Section B (Title V General Requirements) and/or Section E (Source Group Restrictions).

VII. ADDITIONAL REQUIREMENTS.

No additional requirements exist except as provided in other sections of this permit including Section B (Title V General Requirements) and/or Section E (Source Group Restrictions).

***** Permit Shield in Effect. *****

**SECTION D. Source Level Requirements**

Source ID: 311

Source Name: WALKING BEAM REHEAT FURNACE, DANIELI/EQUIVALENT, 421MMBTU/HR

Source Capacity/Throughput:	180.000 Tons/HR	STEEL
	421.700 MCF/HR	Natural Gas

**I. RESTRICTIONS.****Emission Restriction(s).**

001 [25 Pa. Code §123.13]

Processes

No person shall permit the emission into the outdoor atmosphere of particulate matter from Source ID 311 in a manner that the concentration of particulate matter in the effluent gas exceeds 0.04 grain per dry standard cubic foot.

002 [25 Pa. Code §123.21]

General

No person shall permit the emission into the outdoor atmosphere of sulfur dioxide from Source ID 311 in a manner that the concentration of sulfur oxides, expressed as SO₂, in the effluent gas exceeds 500 parts per million, by volume, dry basis.

003 [25 Pa. Code §127.441]

Operating permit terms and conditions.

The Source ID 311 is subject to the following emissions rates:

NO_x: 100 lb/mm scf

CO: 84 lb/mm scf

VOC: 5.5 lb/mm scf

[Additional authority for this permit condition is derived from PA 22-05012E]

004 [25 Pa. Code §127.441]

Operating permit terms and conditions.

The NO_x emissions from Source ID 311 shall not exceed the following rates:

(a) Emission rate of 0.1 lb/mmbtu of heat input, and

(b) 58.41 tons based on a 12-month rolling total, and annual furnace fuel usage of 1,168 mm scf.

[Additional authority for this permit condition is derived from PA 22-05012E]

II. TESTING REQUIREMENTS.

No additional testing requirements exist except as provided in other sections of this permit including Section B (Title V General Requirements).

III. MONITORING REQUIREMENTS.

No additional monitoring requirements exist except as provided in other sections of this permit including Section B (Title V General Requirements).

**SECTION D. Source Level Requirements****IV. RECORDKEEPING REQUIREMENTS.****# 005 [25 Pa. Code §127.441]****Operating permit terms and conditions.**

(a) The permittee shall monitor the source operating hours and fuel usage on a monthly basis and maintain the monthly records in hard copy or electronic format.

(b) The records shall be made available to the Department's representative upon request.

[Additional authority for this permit condition is derived from PA 22-05012E]

V. REPORTING REQUIREMENTS.**# 006 [25 Pa. Code §127.441]****Operating permit terms and conditions.**

The permittee shall report the source's annual operating hours, fuel usage, and the NO_x and CO emissions, with other AIMS emissions reportings in conjunction with the reporting provisions in Section B, Conditions #031 & #032.

[Additional authority for this permit condition is derived from PA 22-05012E]

VI. WORK PRACTICE REQUIREMENTS.

No additional work practice requirements exist except as provided in other sections of this permit including Section B (Title V General Requirements).

VII. ADDITIONAL REQUIREMENTS.

No additional requirements exist except as provided in other sections of this permit including Section B (Title V General Requirements).

***** Permit Shield in Effect. *****

**SECTION D. Source Level Requirements**

Source ID: 311A

Source Name: WBF EMERGENCY GENERATOR

Source Capacity/Throughput:

49.000 Gal/HR

Diesel Fuel

Conditions for this source occur in the following groups: 16

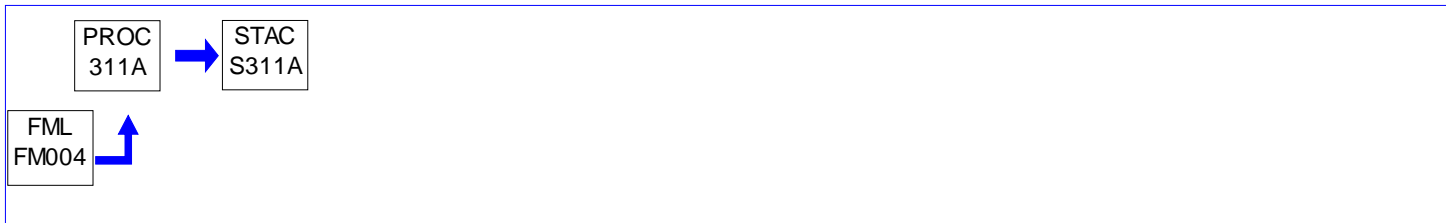
**I. RESTRICTIONS.**

No additional requirements exist except as provided in other sections of this permit including Section B (Title V General Requirements) and/or Section E (Source Group Restrictions).

II. TESTING REQUIREMENTS.

No additional testing requirements exist except as provided in other sections of this permit including Section B (Title V General Requirements) and/or Section E (Source Group Restrictions).

III. MONITORING REQUIREMENTS.

No additional monitoring requirements exist except as provided in other sections of this permit including Section B (Title V General Requirements) and/or Section E (Source Group Restrictions).

IV. RECORDKEEPING REQUIREMENTS.

No additional record keeping requirements exist except as provided in other sections of this permit including Section B (Title V General Requirements) and/or Section E (Source Group Restrictions).

V. REPORTING REQUIREMENTS.

No additional reporting requirements exist except as provided in other sections of this permit including Section B (Title V General Requirements) and/or Section E (Source Group Restrictions).

VI. WORK PRACTICE REQUIREMENTS.

No additional work practice requirements exist except as provided in other sections of this permit including Section B (Title V General Requirements) and/or Section E (Source Group Restrictions).

VII. ADDITIONAL REQUIREMENTS.

No additional requirements exist except as provided in other sections of this permit including Section B (Title V General Requirements) and/or Section E (Source Group Restrictions).

***** Permit Shield in Effect. *****

**SECTION D. Source Level Requirements**

Source ID: 401

Source Name: SOAKING PIT BATTERIES 4-6

Source Capacity/Throughput:	125.000 Tons/HR	STEEL
	175.000 MCF/HR	NATURAL GAS

Conditions for this source occur in the following groups: 03
13
15

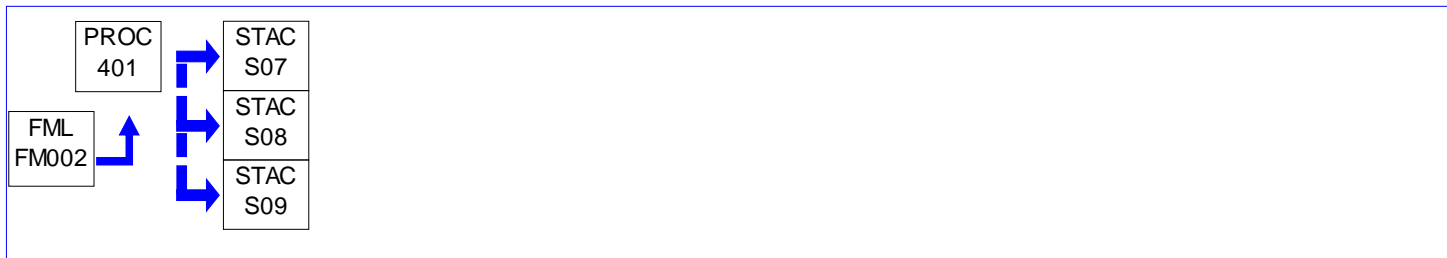
**I. RESTRICTIONS.****Emission Restriction(s).****# 001 [25 Pa. Code §127.441]****Operating permit terms and conditions.**

Source ID 401 is subject to the following restrictions:

- (a) Natural gas usage limit of 309,373 mcf
- (b) NOx emissions of 24.44 tons
- (c) VOC emission limit of 0.85 tons
- (d) The above limits are all based on 12-month rolling total

[Additional authority for this permit condition is derived from PA 22-05012E]

Fuel Restriction(s).**# 002 [25 Pa. Code §127.441]****Operating permit terms and conditions.**

- (a) The permittee has opted to limit the simultaneous operation of only two out of the three remaining soaking pit batteries.

The above paragraph (a) is enforced with the annual fuel usage limit referenced in Condition #001(a), above.

[Additional authority for this permit condition is derived from PA 22-05012E]

II. TESTING REQUIREMENTS.

No additional testing requirements exist except as provided in other sections of this permit including Section B (Title V General Requirements) and/or Section E (Source Group Restrictions).

III. MONITORING REQUIREMENTS.

No additional monitoring requirements exist except as provided in other sections of this permit including Section B (Title V General Requirements) and/or Section E (Source Group Restrictions).

**SECTION D. Source Level Requirements****IV. RECORDKEEPING REQUIREMENTS.****# 003 [25 Pa. Code §127.441]****Operating permit terms and conditions.**

(a) The permittee shall keep monthly and annual records of natural gas usage in Source ID 401. The fuel usage for all pits may be combined.

(b) The fuel usage record may be kept in electronic format. The records shall be made available to the Department's Representative upon request.

[Additional authority for this permit condition is derived from PA 22-05012E]

V. REPORTING REQUIREMENTS.

No additional reporting requirements exist except as provided in other sections of this permit including Section B (Title V General Requirements) and/or Section E (Source Group Restrictions).

VI. WORK PRACTICE REQUIREMENTS.

No additional work practice requirements exist except as provided in other sections of this permit including Section B (Title V General Requirements) and/or Section E (Source Group Restrictions).

VII. ADDITIONAL REQUIREMENTS.**# 004 [25 Pa. Code §127.441]****Operating permit terms and conditions.**

Three out of six soaking pit batteries (Nos. 1, 2, and 3) previously listed under Source ID 401, must remain physically disabled and inoperable pending their disposal. This shall be verifiable with, but not limited to, decoupling of the fuel supply, disengaging the furnace product loading, and by locking these system that no operator may restart this unit without prior notification and a subsequent plan approval from the Department.

[Additional authority for this permit condition is derived from PA 22-05012E]

005 [25 Pa. Code §127.441]**Operating permit terms and conditions.**

Three out of six soaking pits batteries (Nos. 1, 2, and 3) must remain permanently shutdown. If the company plans to bring these shutdown sources back into production, the company shall submit an appropriate plan approval application.

[Additional authority for this permit condition is derived from PA 22-05012E]

***** Permit Shield in Effect. *****

**SECTION D. Source Level Requirements**

Source ID: 500

Source Name: VACUUM DEGASSER @ STEELMAKING

Source Capacity/Throughput: 150.000 Tons/HR STEEL

Conditions for this source occur in the following groups: 13

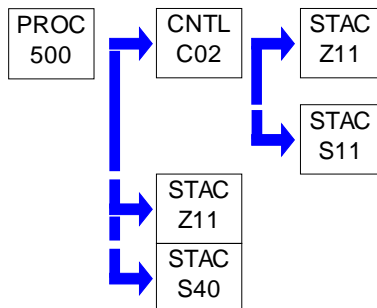
**I. RESTRICTIONS.**

No additional requirements exist except as provided in other sections of this permit including Section B (Title V General Requirements) and/or Section E (Source Group Restrictions).

II. TESTING REQUIREMENTS.

No additional testing requirements exist except as provided in other sections of this permit including Section B (Title V General Requirements) and/or Section E (Source Group Restrictions).

III. MONITORING REQUIREMENTS.

No additional monitoring requirements exist except as provided in other sections of this permit including Section B (Title V General Requirements) and/or Section E (Source Group Restrictions).

IV. RECORDKEEPING REQUIREMENTS.

No additional record keeping requirements exist except as provided in other sections of this permit including Section B (Title V General Requirements) and/or Section E (Source Group Restrictions).

V. REPORTING REQUIREMENTS.

No additional reporting requirements exist except as provided in other sections of this permit including Section B (Title V General Requirements) and/or Section E (Source Group Restrictions).

VI. WORK PRACTICE REQUIREMENTS.

No additional work practice requirements exist except as provided in other sections of this permit including Section B (Title V General Requirements) and/or Section E (Source Group Restrictions).

VII. ADDITIONAL REQUIREMENTS.

No additional requirements exist except as provided in other sections of this permit including Section B (Title V General Requirements) and/or Section E (Source Group Restrictions).

***** Permit Shield in Effect. *****

**SECTION D. Source Level Requirements**

Source ID: 501A

Source Name: #207 DCEAF

Source Capacity/Throughput:	163.000 Tons/HR	STEEL
	93.000 MCF/HR	NATURAL GAS

Conditions for this source occur in the following groups: 09
10
11
13
15

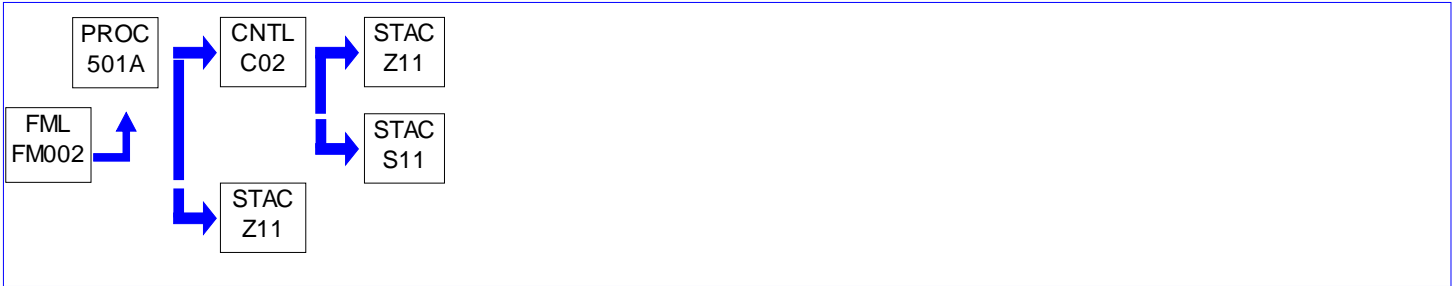
**I. RESTRICTIONS.****Emission Restriction(s).****# 001 [25 Pa. Code §127.441]****Operating permit terms and conditions.**

Annual steel production from the melt shop shall not exceed 1.24 million tons, based on 12-month rolling total.

[Additional authority for this permit condition is derived from operating permit No. 22-307-034B]

002 [25 Pa. Code §127.441]**Operating permit terms and conditions.**

The following are the allowable emission rates for the Melt Shop by specific pollutant, and opacity when producing steel from DCEAF:

- (a) Sulfur Dioxide (SO₂) emissions shall not exceed 40 lb/hr on a three-hour average, or any three continuous cycles of steel production in the electric arc furnace from start of charge to finish of tap. Total annual SO₂ emissions shall not exceed 149 tons, based on 12-month rolling total.
- (b) Carbon Monoxide (CO) emissions shall not exceed 251 lb/hr on a daily average as measured by a certified continuous emissions monitor. Total annual CO emissions shall not exceed 955 tons, based on 12-month rolling total.
- (c) Lead emissions shall not exceed 0.54 lb/hr and 2 tpy.
- (d) NO_x emissions shall not exceed 26.1 lb/hr on a daily average as measured by a certified continuous emissions monitor.
- (e) VOC emissions shall not exceed 21.2 lb/hr.

[Additional authority for this permit condition is derived from operating permit No. 22-307-034B]

003 [25 Pa. Code §127.512]**Operating permit terms and conditions.**

Particulate matter emissions shall not exceed 0.003 gr/dscf, 32 lb/hr, and 122 tons per year.

[Additional authority for this permit condition is derived from operating permit No. 22-307-034B]

**SECTION D. Source Level Requirements****II. TESTING REQUIREMENTS.****# 004 [25 Pa. Code §127.441]****Operating permit terms and conditions.**

The control system shall be tested for Particulate Matter, VOCs, and lead emissions unless otherwise approved in writing by DEP. The stack tests are to be conducted within 180 days prior to expiration of the permit unless otherwise approved in writing by DEP.

[Additional authority for this permit condition is derived from operating permit No. 22-307-034B]

III. MONITORING REQUIREMENTS.**# 005 [25 Pa. Code §127.441]****Operating permit terms and conditions.**

The permittee shall visually inspect the upper chamber of #2 Baghouse for worn, frayed, or defective bags on a monthly basis. Worn, frayed, or defective bags shall be replaced within two weeks following the inspection.

[Additional authority for this permit condition is derived from operating permit No. 22-307-034B]

IV. RECORDKEEPING REQUIREMENTS.**# 006 [25 Pa. Code §127.441]****Operating permit terms and conditions.**

The permittee shall maintain records of the daily readings of the pressure differential across each of the 20 compartments of the baghouse, as well as the weekly average.

007 [25 Pa. Code §127.441]**Operating permit terms and conditions.**

The permittee shall maintain a log of the inspection and maintenance activities. The log shall be signed and dated by the person responsible for making the inspection and/or repair. This log shall be kept on-site and produced to the Department upon request.

[Additional authority for this permit condition is derived from operating permit No. 22-307-034B]

V. REPORTING REQUIREMENTS.

No additional reporting requirements exist except as provided in other sections of this permit including Section B (Title V General Requirements) and/or Section E (Source Group Restrictions).

VI. WORK PRACTICE REQUIREMENTS.**# 008 [25 Pa. Code §127.441]****Operating permit terms and conditions.**

The permittee shall operate and maintain gauges to measure the pressure differential across each of the 20 compartments of the baghouse. The gauges shall measure the pressure differential of the inlet and outlet of the respective fabric collector.

VII. ADDITIONAL REQUIREMENTS.**# 009 [25 Pa. Code §127.441]****Operating permit terms and conditions.**

(a) Source ID 501A is rated at 163 tons/hour; 150 tons/tap and 1.24 million tons/year.

(b) The oxyfuel burners (four Side Wall Oxy-fuel Burners of 5 MW each and one Sump Oxy-fuel Burner of 2.5 MW) are incorporated into the Source ID 501A.

(c) The #2 Baghouse Controls the particulate matter emissions from the steelmaking operations in melt shop: Source ID 501A (DCEAF), Source ID 501B (LRF), and Melt Shop Roof Monitor.

**SECTION D. Source Level Requirements**

[Additional authority for this permit condition is derived from operating permit No. 22-307-034B]

***** Permit Shield in Effect. *****

**SECTION D. Source Level Requirements**

Source ID: 501B

Source Name: LADLE REFINING FURNACE

Source Capacity/Throughput: 163.000 Tons/HR STEEL

Conditions for this source occur in the following groups: 09
10
13
15

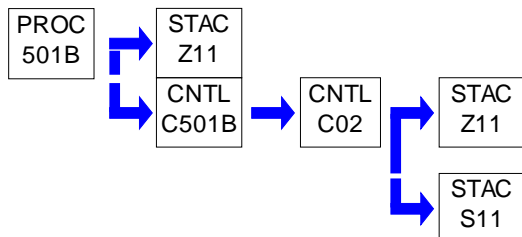
**I. RESTRICTIONS.****Emission Restriction(s).****# 001 [25 Pa. Code §127.441]****Operating permit terms and conditions.**

Sulfur Dioxide (SO₂) emissions from SO₂ Scrubber shall not exceed 40 lb/hr on a three-hour average, or any three continuous cycles of steel production in the electric arc furnace from start of charge to finish of tap. Total annual SO₂ emissions shall not exceed 149 tons, based on 12-month rolling total.

II. TESTING REQUIREMENTS.**# 002 [25 Pa. Code §127.444]****Compliance requirements.**

(a) Unless otherwise approved in writing by DEP, the SO₂ control system shall be tested for SO₂ emissions once during the life of the permit, no earlier than twenty-four (24) months prior to the expiration of this permit.

(b) The stack testing shall be performed, and the tests shall be reported in accordance with Section C, Condition #009.

III. MONITORING REQUIREMENTS.**# 003 [25 Pa. Code §127.441]****Operating permit terms and conditions.**

(a) The permittee shall use the approved process parameter(s) or indicator(s) to obtain data and monitor the emission control equipment performance, when the source is operating.

- (1) Minimum soda ash use (Control ID: C501B)
- (2) SO₂ dry scrubber pressure differential (Control ID: C501B)

(b) The permittee shall use the approved means or devices to measure the applicable indicator(s).

- (1) Soda ash use – programmable automated mixing system
- (2) Pressure Drop - pressure gauges or manometers

(c) The permittee shall use the approved frequency for condition monitoring of indicator(s).

- (1) Soda ash use - continuously, when the source is operating
- (2) Baghouse pressure differential – continuously, when the source is operating

**SECTION D. Source Level Requirements**

(d) The permittee shall use the approved period over which discrete data points for approved indicator(s) will be collected for the purpose of determining an excursion.

(1) Soda ash use recorded at least once per day while the source(s) and respective controls are operating and averaged on a weekly basis.

(2) Baghouse pressure differential recorded at least once per day while the source(s) and respective controls are operating and averaged on a weekly basis.

[Additional authority for the following Compliance Assurance Monitoring (CAM) permit conditions is derived from 40 CFR Part 64.6]

IV. RECORDKEEPING REQUIREMENTS.**# 004 [25 Pa. Code §127.441]****Operating permit terms and conditions.**

(a) The permittee shall maintain records of the following information:

(1) Soda ash use – daily

(2) Pressure differential across the baghouse - daily

(b) The permittee shall record all excursions and corrective actions taken in response to an excursion and the time elapsed until the corrective actions have been taken.

(c) The permittee shall maintain records of applicable monitoring downtime incidents (other than downtime associated with zero and span or other daily calibration checks, if applicable). The permittee shall also record the dates, times and durations, possible causes and corrective actions taken for the incidents.

(d) These records shall be maintained on site for the most recent five year period and made available to the Department upon request.

[Additional authority for this Compliance Assurance Monitoring (CAM) permit condition is also derived from 40 CFR Part 64, Section 64.9 and 40 CFR Part 70, Section 70.6(a)(3)(ii)(B)]

V. REPORTING REQUIREMENTS.**# 005 [25 Pa. Code §127.441]****Operating permit terms and conditions.**

(a) The permittee shall report all excursions, corrective actions taken, dates, times, durations, and possible causes of the events to the Department, in accordance with the annual and semi-annual Compliance Certification reports required in Section B, Conditions #025 and #026.

(b) The permittee shall report applicable monitoring downtime incidents (other than downtime associated with zero and span or other daily calibration checks, if applicable), their dates, times, durations, possible causes, and corrective actions taken, to the Department, in accordance with the semi-annual Compliance Certification report.

[Additional authority for this Compliance Assurance Monitoring (CAM) permit condition is also derived from 40 CFR Part 64, Section 64.9 and 40 CFR Part 70, Section 70.6(a)(3)(iii)(A)]

VI. WORK PRACTICE REQUIREMENTS.**# 006 [25 Pa. Code §127.441]****Operating permit terms and conditions.**

(a) The permittee shall use the approved range for each selected indicator in determining the appropriate operation of the sources. A departure from the specified indicator range shall be defined as an excursion.

(1) Minimum soda ash use shall be greater than 10 lb/hr, based on a weekly average

**SECTION D. Source Level Requirements**

(2) Baghouse pressure differential shall be greater than 0.1" water, based on a weekly average

(b) For QA/QC practices, the permittee shall calibrate and check the accuracy of monitoring equipment taking into account the manufacturer's specifications at approved time intervals.

(1) Soda ash automated mixing system shall be calibrated in accordance to the manufacturer's specifications and/or good operating practices.

(2) Baghouse pressure differential gauges shall be calibrated annually

[Additional authority for this Compliance Assurance Monitoring (CAM) permit condition is also derived from 40 CFR Part 64, Sections 64.3 & 64.6]

VII. ADDITIONAL REQUIREMENTS.**# 007 [25 Pa. Code §127.441]****Operating permit terms and conditions.**

(a) The permittee shall develop and implement a quality improvement plan (QIP) as expeditiously as practicable if any of the following occurs:

(1) Six (6) excursions of any given parameter, for any given source, occur in a six-month period.

(2) The Department determines after review of all reported information that the permittee has not responded acceptably to an excursion.

(b) The QIP shall be developed and submitted to the Department within 60 days, unless otherwise approved in writing by the Department, and the permittee shall provide a copy of the QIP to the Department upon request. Furthermore, the permittee shall notify the Department if the period for completing the improvements contained in the QIP exceeds 180 days from the date on which the need to implement the QIP was determined.

(c) The permittee shall record actions taken to implement a QIP during a reporting period and all related actions including, but not limited to, inspections, repairs and maintenance performed on the monitoring equipment.

(d) In accordance with 40 CFR Section 64.8, the QIP shall include procedures for evaluating the control performance problems. Based on the results of the evaluation procedures, the QIP shall be modified to include procedures for conducting more frequent or improved monitoring in conjunction with one or more of the following:

(1) Improved preventive maintenance practices.

(2) Process operation changes.

(3) Appropriate improvements to control methods.

(4) Other steps appropriate to correct performance.

(e) Following implementation of a QIP, the Department will require reasonable revisions to the QIP if the plan has failed to either:

(1) Address the cause of the control device performance problem.

(2) Provide adequate procedures for correcting control device performance problems in as expeditiously as practicable in accordance with good air pollution control practices for minimizing emissions.

(f) Implementation of a QIP shall not excuse the permittee from compliance with any existing emission limitation or standard or any existing monitoring, testing, reporting or recordkeeping requirements that apply under any federal, state, or local laws or any other applicable requirements under the Clean Air Act.

[Additional authority for this Compliance Assurance Monitoring (CAM) permit condition is also derived from 40 CFR Part 64, Sections 64.8 & 64.9]

008 [25 Pa. Code §127.441]**Operating permit terms and conditions.**

**SECTION D. Source Level Requirements**

The following are the list of controls on Source ID 501B (LRF) and steel refining operations:

- (a) SO₂ Dry Scrubber controls the gaseous emissions from LRF.
- (b) Bin Vent Filter #2 controls Soda Ash Silo for SO₂ Dry Scrubber.

***** Permit Shield in Effect. *****

**SECTION D. Source Level Requirements**

Source ID: 504

Source Name: COAL STORAGE SILO

Source Capacity/Throughput:

N/A

COAL

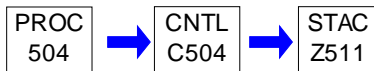
**I. RESTRICTIONS.**

No additional requirements exist except as provided in other sections of this permit including Section B (Title V General Requirements).

II. TESTING REQUIREMENTS.

No additional testing requirements exist except as provided in other sections of this permit including Section B (Title V General Requirements).

III. MONITORING REQUIREMENTS.

No additional monitoring requirements exist except as provided in other sections of this permit including Section B (Title V General Requirements).

IV. RECORDKEEPING REQUIREMENTS.

No additional record keeping requirements exist except as provided in other sections of this permit including Section B (Title V General Requirements).

V. REPORTING REQUIREMENTS.

No additional reporting requirements exist except as provided in other sections of this permit including Section B (Title V General Requirements).

VI. WORK PRACTICE REQUIREMENTS.

No additional work practice requirements exist except as provided in other sections of this permit including Section B (Title V General Requirements).

VII. ADDITIONAL REQUIREMENTS.

No additional requirements exist except as provided in other sections of this permit including Section B (Title V General Requirements).

***** Permit Shield in Effect. *****

**SECTION D. Source Level Requirements**

Source ID: 505

Source Name: COAL STORAGE SILO

Source Capacity/Throughput:

N/A

SPAR COAL

**I. RESTRICTIONS.**

No additional requirements exist except as provided in other sections of this permit including Section B (Title V General Requirements).

II. TESTING REQUIREMENTS.

No additional testing requirements exist except as provided in other sections of this permit including Section B (Title V General Requirements).

III. MONITORING REQUIREMENTS.

No additional monitoring requirements exist except as provided in other sections of this permit including Section B (Title V General Requirements).

IV. RECORDKEEPING REQUIREMENTS.

No additional record keeping requirements exist except as provided in other sections of this permit including Section B (Title V General Requirements).

V. REPORTING REQUIREMENTS.

No additional reporting requirements exist except as provided in other sections of this permit including Section B (Title V General Requirements).

VI. WORK PRACTICE REQUIREMENTS.

No additional work practice requirements exist except as provided in other sections of this permit including Section B (Title V General Requirements).

VII. ADDITIONAL REQUIREMENTS.

No additional requirements exist except as provided in other sections of this permit including Section B (Title V General Requirements).

***** Permit Shield in Effect. *****

**SECTION D. Source Level Requirements**

Source ID: 510

Source Name: #2 BAGHOUSE DUST PNEUMATIC SYSTEM

Source Capacity/Throughput:

N/A

IRON OXIDE DUST

Conditions for this source occur in the following groups: 11

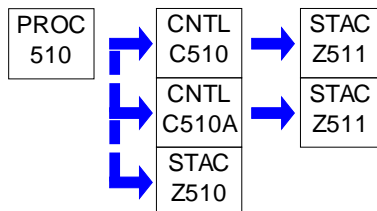
**I. RESTRICTIONS.**

No additional requirements exist except as provided in other sections of this permit including Section B (Title V General Requirements) and/or Section E (Source Group Restrictions).

II. TESTING REQUIREMENTS.

No additional testing requirements exist except as provided in other sections of this permit including Section B (Title V General Requirements) and/or Section E (Source Group Restrictions).

III. MONITORING REQUIREMENTS.

No additional monitoring requirements exist except as provided in other sections of this permit including Section B (Title V General Requirements) and/or Section E (Source Group Restrictions).

IV. RECORDKEEPING REQUIREMENTS.

No additional record keeping requirements exist except as provided in other sections of this permit including Section B (Title V General Requirements) and/or Section E (Source Group Restrictions).

V. REPORTING REQUIREMENTS.

No additional reporting requirements exist except as provided in other sections of this permit including Section B (Title V General Requirements) and/or Section E (Source Group Restrictions).

VI. WORK PRACTICE REQUIREMENTS.

No additional work practice requirements exist except as provided in other sections of this permit including Section B (Title V General Requirements) and/or Section E (Source Group Restrictions).

VII. ADDITIONAL REQUIREMENTS.

No additional requirements exist except as provided in other sections of this permit including Section B (Title V General Requirements) and/or Section E (Source Group Restrictions).

***** Permit Shield in Effect. *****

**SECTION D. Source Level Requirements**

Source ID: 511

Source Name: LIME INJECTION SILO

Source Capacity/Throughput:

N/A

LIME

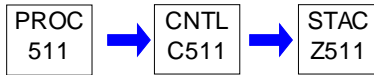
**I. RESTRICTIONS.**

No additional requirements exist except as provided in other sections of this permit including Section B (Title V General Requirements).

II. TESTING REQUIREMENTS.

No additional testing requirements exist except as provided in other sections of this permit including Section B (Title V General Requirements).

III. MONITORING REQUIREMENTS.

No additional monitoring requirements exist except as provided in other sections of this permit including Section B (Title V General Requirements).

IV. RECORDKEEPING REQUIREMENTS.

No additional record keeping requirements exist except as provided in other sections of this permit including Section B (Title V General Requirements).

V. REPORTING REQUIREMENTS.

No additional reporting requirements exist except as provided in other sections of this permit including Section B (Title V General Requirements).

VI. WORK PRACTICE REQUIREMENTS.

No additional work practice requirements exist except as provided in other sections of this permit including Section B (Title V General Requirements).

VII. ADDITIONAL REQUIREMENTS.

No additional requirements exist except as provided in other sections of this permit including Section B (Title V General Requirements).

***** Permit Shield in Effect. *****

**SECTION D. Source Level Requirements**

Source ID: 513

Source Name: LIME SILO, LRF

Source Capacity/Throughput:

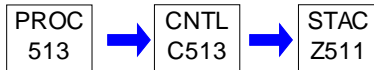
**I. RESTRICTIONS.**

No additional requirements exist except as provided in other sections of this permit including Section B (Title V General Requirements).

II. TESTING REQUIREMENTS.

No additional testing requirements exist except as provided in other sections of this permit including Section B (Title V General Requirements).

III. MONITORING REQUIREMENTS.

No additional monitoring requirements exist except as provided in other sections of this permit including Section B (Title V General Requirements).

IV. RECORDKEEPING REQUIREMENTS.

No additional record keeping requirements exist except as provided in other sections of this permit including Section B (Title V General Requirements).

V. REPORTING REQUIREMENTS.

No additional reporting requirements exist except as provided in other sections of this permit including Section B (Title V General Requirements).

VI. WORK PRACTICE REQUIREMENTS.

No additional work practice requirements exist except as provided in other sections of this permit including Section B (Title V General Requirements).

VII. ADDITIONAL REQUIREMENTS.

No additional requirements exist except as provided in other sections of this permit including Section B (Title V General Requirements).

***** Permit Shield in Effect. *****

**SECTION D. Source Level Requirements**

Source ID: 514

Source Name: SODA ASH STORAGE SILO, SO2

Source Capacity/Throughput:

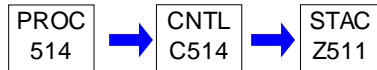
**I. RESTRICTIONS.**

No additional requirements exist except as provided in other sections of this permit including Section B (Title V General Requirements).

II. TESTING REQUIREMENTS.

No additional testing requirements exist except as provided in other sections of this permit including Section B (Title V General Requirements).

III. MONITORING REQUIREMENTS.

No additional monitoring requirements exist except as provided in other sections of this permit including Section B (Title V General Requirements).

IV. RECORDKEEPING REQUIREMENTS.

No additional record keeping requirements exist except as provided in other sections of this permit including Section B (Title V General Requirements).

V. REPORTING REQUIREMENTS.

No additional reporting requirements exist except as provided in other sections of this permit including Section B (Title V General Requirements).

VI. WORK PRACTICE REQUIREMENTS.

No additional work practice requirements exist except as provided in other sections of this permit including Section B (Title V General Requirements).

VII. ADDITIONAL REQUIREMENTS.

No additional requirements exist except as provided in other sections of this permit including Section B (Title V General Requirements).

***** Permit Shield in Effect. *****

**SECTION D. Source Level Requirements**

Source ID: 921

Source Name: PARTS WASHERS

Source Capacity/Throughput:

N/A

SOLVENT

Conditions for this source occur in the following groups: 13

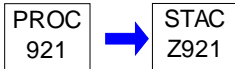
**I. RESTRICTIONS.****Emission Restriction(s).****# 001 [25 Pa. Code §129.63]****Degreasing operations**

The permittee may not use, sell or offer for sale for use in a cold cleaning machine any solvent with a vapor pressure of 1.0 millimeter or mercury (mm Hg) or greater and containing greater than 5% VOC by weight, measured at 20°C (68°F) containing VOCs.

The above requirement does not apply:

- (a) To cold cleaning machines used in extreme cleaning service.
- (b) If the permittee demonstrates, and the Department approves in writing, that compliance with these conditions will result in unsafe operating conditions.
- (c) To immersion cold cleaning machines with a freeboard ratio equal to or greater than 0.75.

Throughput Restriction(s).**# 002 [25 Pa. Code §129.63]****Degreasing operations**

Immersion cold cleaning machines shall have a freeboard ratio of 0.50 or greater.

II. TESTING REQUIREMENTS.

No additional testing requirements exist except as provided in other sections of this permit including Section B (Title V General Requirements) and/or Section E (Source Group Restrictions).

III. MONITORING REQUIREMENTS.

No additional monitoring requirements exist except as provided in other sections of this permit including Section B (Title V General Requirements) and/or Section E (Source Group Restrictions).

IV. RECORDKEEPING REQUIREMENTS.**# 003 [25 Pa. Code §129.63]****Degreasing operations**

(a) The permittee shall maintain for at least two (2) years and shall provide to the Department, on request, the following information:

- (i) The name and address of the solvent supplier.
- (ii) The type of solvent including the product or vendor identification number.
- (iii) The vapor pressure of the solvent measured in mm Hg at 20°C (68°F).

**SECTION D. Source Level Requirements**

(b) An invoice, bill of sale, certificate that corresponds to a number of sales, Material Safety Data Sheet (MSDS), or other appropriate documentation acceptable to the Department may be used to comply with this section.

V. REPORTING REQUIREMENTS.

No additional reporting requirements exist except as provided in other sections of this permit including Section B (Title V General Requirements) and/or Section E (Source Group Restrictions).

VI. WORK PRACTICE REQUIREMENTS.**# 004 [25 Pa. Code §129.63]****Degreasing operations**

The permittee shall operate the cold cleaning machines in accordance with the following procedures:

- (i) Waste solvent shall be collected and stored in closed containers. The closed containers may contain a device that allows pressure relief, but does not allow liquid solvent to drain from the container.
- (ii) Flushing of parts using a flexible hose or other flushing device shall be performed only within the cold cleaning machine. The solvent spray shall be a solid fluid stream, not an atomized or shower spray.
- (iii) Sponges, fabric, wood, leather, paper products and other absorbent materials may not be cleaned in the cold cleaning machine.
- (iv) Air agitated solvent baths may not be used.
- (v) Spills during solvent transfer and use of the cold cleaning machine shall be cleaned up immediately.

005 [25 Pa. Code §129.63]**Degreasing operations**

Immersion cold cleaning machines shall be equipped with a cover that shall be closed at all times except during cleaning of parts or the addition or removal of solvent. For remote reservoir cold cleaning machines which drain directly into the solvent storage reservoir, a perforated drain with a diameter of not more than six (6) inches shall constitute an acceptable cover.

006 [25 Pa. Code §129.63]**Degreasing operations**

For immersion cold cleaning machines and remote reservoir cold cleaning machines, the permittee shall:

Have a permanent, conspicuous label summarizing the operating requirements in Section D, Condition #005. In addition, the label shall include the following discretionary good operating practices:

- (a) Cleaned parts should be drained at least 15 seconds or until dripping ceases, whichever is longer. Parts having cavities or blind holes shall be tipped or rotated while the part is draining. During the draining, tipping or rotating, the parts should be positioned so that solvent drains directly back to the cold cleaning machine.
- (b) When a pump-agitated solvent bath is used, the agitator should be operated to produce a rolling motion of the solvent with no observable splashing of the solvent against the tank walls or the parts being cleaned.
- (c) Work area fans should be located and positioned so that they do not blow across the opening of the degreaser unit.

VII. ADDITIONAL REQUIREMENTS.**# 007 [25 Pa. Code §129.63]****Degreasing operations**

The permittee that operates a parts washer or cold cleaning machines that use 2 gallons or more of solvents containing greater than 5% VOC content by weight for the cleaning of metal parts shall comply with the requirements listed in this



SECTION D. Source Level Requirements

section.

***** Permit Shield in Effect. *****

**SECTION D. Source Level Requirements**

Source ID: 922

Source Name: COMPRESSED AIR SYSTEM FREEZE PROTECTION

Source Capacity/Throughput:

Conditions for this source occur in the following groups: 13

15

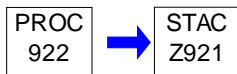
**I. RESTRICTIONS.**

No additional requirements exist except as provided in other sections of this permit including Section B (Title V General Requirements) and/or Section E (Source Group Restrictions).

II. TESTING REQUIREMENTS.

No additional testing requirements exist except as provided in other sections of this permit including Section B (Title V General Requirements) and/or Section E (Source Group Restrictions).

III. MONITORING REQUIREMENTS.

No additional monitoring requirements exist except as provided in other sections of this permit including Section B (Title V General Requirements) and/or Section E (Source Group Restrictions).

IV. RECORDKEEPING REQUIREMENTS.

No additional record keeping requirements exist except as provided in other sections of this permit including Section B (Title V General Requirements) and/or Section E (Source Group Restrictions).

V. REPORTING REQUIREMENTS.

No additional reporting requirements exist except as provided in other sections of this permit including Section B (Title V General Requirements) and/or Section E (Source Group Restrictions).

VI. WORK PRACTICE REQUIREMENTS.

No additional work practice requirements exist except as provided in other sections of this permit including Section B (Title V General Requirements) and/or Section E (Source Group Restrictions).

VII. ADDITIONAL REQUIREMENTS.

No additional requirements exist except as provided in other sections of this permit including Section B (Title V General Requirements) and/or Section E (Source Group Restrictions).

***** Permit Shield in Effect. *****

**SECTION D. Source Level Requirements**

Source ID: 924

Source Name: ROAD DUST EMISSIONS

Source Capacity/Throughput:

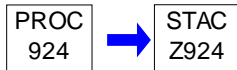
**I. RESTRICTIONS.**

No additional requirements exist except as provided in other sections of this permit including Section B (Title V General Requirements).

II. TESTING REQUIREMENTS.

No additional testing requirements exist except as provided in other sections of this permit including Section B (Title V General Requirements).

III. MONITORING REQUIREMENTS.

No additional monitoring requirements exist except as provided in other sections of this permit including Section B (Title V General Requirements).

IV. RECORDKEEPING REQUIREMENTS.

No additional record keeping requirements exist except as provided in other sections of this permit including Section B (Title V General Requirements).

V. REPORTING REQUIREMENTS.

No additional reporting requirements exist except as provided in other sections of this permit including Section B (Title V General Requirements).

VI. WORK PRACTICE REQUIREMENTS.

No additional work practice requirements exist except as provided in other sections of this permit including Section B (Title V General Requirements).

VII. ADDITIONAL REQUIREMENTS.

No additional requirements exist except as provided in other sections of this permit including Section B (Title V General Requirements).

***** Permit Shield in Effect. *****

**SECTION D. Source Level Requirements**

Source ID: 926A

Source Name: WATER TREATMENT,BLR/PROC/VACDEG/CASTER

Source Capacity/Throughput:

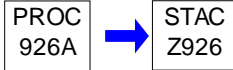
**I. RESTRICTIONS.**

No additional requirements exist except as provided in other sections of this permit including Section B (Title V General Requirements).

II. TESTING REQUIREMENTS.

No additional testing requirements exist except as provided in other sections of this permit including Section B (Title V General Requirements).

III. MONITORING REQUIREMENTS.

No additional monitoring requirements exist except as provided in other sections of this permit including Section B (Title V General Requirements).

IV. RECORDKEEPING REQUIREMENTS.

No additional record keeping requirements exist except as provided in other sections of this permit including Section B (Title V General Requirements).

V. REPORTING REQUIREMENTS.

No additional reporting requirements exist except as provided in other sections of this permit including Section B (Title V General Requirements).

VI. WORK PRACTICE REQUIREMENTS.

No additional work practice requirements exist except as provided in other sections of this permit including Section B (Title V General Requirements).

VII. ADDITIONAL REQUIREMENTS.

No additional requirements exist except as provided in other sections of this permit including Section B (Title V General Requirements).

***** Permit Shield in Effect. *****

**SECTION E. Source Group Restrictions.**

Group Name: 02

Group Description: Hot rolling operations (44", 28/35", and 20" mills)

Sources included in this group

ID	Name
132A	44" MILL HOT ROLLING OPERATIONS
132B	28"/35" MILL HOT ROLLING OPERATIONS
132C	20" MILL HOT ROLLING OPERATIONS

I. RESTRICTIONS.

No additional requirements exist except as provided in other sections of this permit including Section B (Title V General Requirements).

II. TESTING REQUIREMENTS.

No additional testing requirements exist except as provided in other sections of this permit including Section B (Title V General Requirements).

III. MONITORING REQUIREMENTS.

No additional monitoring requirements exist except as provided in other sections of this permit including Section B (Title V General Requirements).

IV. RECORDKEEPING REQUIREMENTS.**# 001 [25 Pa. Code §127.441]****Operating permit terms and conditions.**

The permittee shall record the operating hours and the VOC emissions from hot rolling operations on an annual basis. The records shall be made available to the Department's representative upon request.

V. REPORTING REQUIREMENTS.**# 002 [25 Pa. Code §127.441]****Operating permit terms and conditions.**

Annual report on the VOC emissions shall be submitted to the Department in conjunction with Section B, Conditions #031 & #032.

VI. WORK PRACTICE REQUIREMENTS.

No additional work practice requirements exist except as provided in other sections of this permit including Section B (Title V General Requirements).

VII. ADDITIONAL REQUIREMENTS.

No additional requirements exist except as provided in other sections of this permit including Section B (Title V General Requirements).

***** Permit Shield in Effect. *****

**SECTION E. Source Group Restrictions.**

Group Name: 03

Group Description: Soaking pits, 20 inch mill subject to testing

Sources included in this group

ID	Name
232C	20" MILL REHEAT FURNACE
401	SOAKING PIT BATTERIES 4-6

I. RESTRICTIONS.**Emission Restriction(s).****# 001 [25 Pa. Code §123.13]****Processes**

No person shall permit the emission into the outdoor atmosphere of particulate matter from each one of the sources in a manner that the concentration of particulate matter in the effluent gas exceeds 0.04 grain per dry standard cubic foot.

002 [25 Pa. Code §123.21]**General**

No person shall permit the emission into the outdoor atmosphere of sulfur dioxide from each one of the sources in a manner that the concentration of sulfur oxides, expressed as SO₂, in the effluent gas exceeds 500 parts per million, by volume, dry basis.

II. TESTING REQUIREMENTS.**# 003 [25 Pa. Code §127.441]****Operating permit terms and conditions.**

(a) Unless otherwise approved in writing by DEP, stack testing to determine the emissions rate of NO_x as NO₂ shall be performed once during each permit term under normal operating conditions on each of the following:

- (1) On one representative stack of the equipment under Source ID 401, Soaking Pit Batteries 4-6,
- (2) Source ID 232C, 20" Mill Reheat Furnace.

(b) The stack testing and reporting shall comply with Section C, Condition #009. Results shall be reported as follows:

- (1) Concentration in ppm as measured
- (2) Mass and heat rates in lb/hr and lb/mmbtu

III. MONITORING REQUIREMENTS.

No additional monitoring requirements exist except as provided in other sections of this permit including Section B (Title V General Requirements).

IV. RECORDKEEPING REQUIREMENTS.

No additional record keeping requirements exist except as provided in other sections of this permit including Section B (Title V General Requirements).

V. REPORTING REQUIREMENTS.

No additional reporting requirements exist except as provided in other sections of this permit including Section B (Title V General Requirements).

VI. WORK PRACTICE REQUIREMENTS.

No additional work practice requirements exist except as provided in other sections of this permit including Section B (Title V General Requirements).

**SECTION E. Source Group Restrictions.****VII. ADDITIONAL REQUIREMENTS.**

No additional requirements exist except as provided in other sections of this permit including Section B (Title V General Requirements).

***** Permit Shield in Effect. *****

**SECTION E. Source Group Restrictions.**

Group Name: 04

Group Description: Comb. sources 1-10 mmbtu/hr for melt shop & caster, ladle/tundish preheaters & dryer, cooling

Sources included in this group

ID	Name
102	CONTROLLED COOLING BOXES 1 - 8
109	EAF LADLE PREHEATERS 1-4
114	CONTIN. CASTER TUNDISH PREHTR. 1 & 2
116	CONTINUOUS CASTER TUNDISH DRYER 1

I. RESTRICTIONS.**Emission Restriction(s).**

001 [25 Pa. Code §123.21]

General

No person shall permit the emission into the outdoor atmosphere of sulfur dioxide from each one of the sources in a manner that the concentration of sulfur oxides, expressed as SO₂, in the effluent gas exceeds 500 parts per million, by volume, dry basis.

II. TESTING REQUIREMENTS.

No additional testing requirements exist except as provided in other sections of this permit including Section B (Title V General Requirements).

III. MONITORING REQUIREMENTS.

No additional monitoring requirements exist except as provided in other sections of this permit including Section B (Title V General Requirements).

IV. RECORDKEEPING REQUIREMENTS.

No additional record keeping requirements exist except as provided in other sections of this permit including Section B (Title V General Requirements).

V. REPORTING REQUIREMENTS.

No additional reporting requirements exist except as provided in other sections of this permit including Section B (Title V General Requirements).

VI. WORK PRACTICE REQUIREMENTS.

No additional work practice requirements exist except as provided in other sections of this permit including Section B (Title V General Requirements).

VII. ADDITIONAL REQUIREMENTS.

No additional requirements exist except as provided in other sections of this permit including Section B (Title V General Requirements).

***** Permit Shield in Effect. *****

**SECTION E. Source Group Restrictions.**

Group Name: 05

Group Description: Combustion sources 2.5-20 mmbtu/hr

Sources included in this group

ID	Name
033	PLANT HOT WATER HEATERS
034	SHOP SPACE HEATERS
118	CASTER CUTTING TORCHES 1-6
129	RAILROAD CAR INGOT HEATERS
138	SCRAP PREPARATION

I. RESTRICTIONS.**Emission Restriction(s).**

001 [25 Pa. Code §123.21]

General

No person shall permit the emission into the outdoor atmosphere of sulfur dioxide from each one of the sources in a manner that the concentration of sulfur oxides, expressed as SO₂, in the effluent gas exceeds 500 parts per million, by volume, dry basis.

II. TESTING REQUIREMENTS.

No additional testing requirements exist except as provided in other sections of this permit including Section B (Title V General Requirements).

III. MONITORING REQUIREMENTS.

No additional monitoring requirements exist except as provided in other sections of this permit including Section B (Title V General Requirements).

IV. RECORDKEEPING REQUIREMENTS.

002 [25 Pa. Code §127.441]

Operating permit terms and conditions.

(a) For the above listed sources, the permittee shall keep record of monthly usage of fuel, and calculation of NO_x and VOC emissions.

(b) The fuel usage may be measured in groups.

V. REPORTING REQUIREMENTS.

No additional reporting requirements exist except as provided in other sections of this permit including Section B (Title V General Requirements).

VI. WORK PRACTICE REQUIREMENTS.

No additional work practice requirements exist except as provided in other sections of this permit including Section B (Title V General Requirements).

VII. ADDITIONAL REQUIREMENTS.

No additional requirements exist except as provided in other sections of this permit including Section B (Title V General Requirements).

***** Permit Shield in Effect. *****

**SECTION E. Source Group Restrictions.**

Group Name: 08

Group Description: Boiler State Requirements

Sources included in this group

ID	Name
032A	BOILER (ZURN, 14M-350)
035A	BOILER (YORK-SHIPLEY, 582-SPH-650-XID)

I. RESTRICTIONS.**Emission Restriction(s).****# 001 [25 Pa. Code §123.11]****Combustion units**

A person may not permit the emission into the outdoor atmosphere of particulate matter from each of the combustion units in excess of 0.4 pound per million Btu of heat input.

(a) A person may not permit the emission into the outdoor atmosphere of particulate matter from a combustion unit in excess of the following:

(1) The rate of 0.4 pound per million Btu of heat input, when the heat input to the combustion unit in millions of Btus per hour is greater than 2.5 but less than 50.

(2) The rate determined by the following formula:

$$A = 3.6E^{-0.56}$$

where:

A = Allowable emissions in pounds per million Btus of heat input, and

E = Heat input to the combustion unit in millions of Btus per hour, when E is equal to or greater than 50 but less than 600. (At capacity of 99 mmBtu/hr, A = 0.275 lb/mmBtu)

002 [25 Pa. Code §123.22]**Combustion units**

No person shall permit the emission into the outdoor atmosphere of sulfur oxides, expressed as sulfur dioxide, from a combustion unit in excess of the rate of four (4) pounds per million Btu of heat input over any 1-hour period.

003 [25 Pa. Code §127.512]**Operating permit terms and conditions.**

Sulfur oxide emissions shall not exceed the following when combusting natural gas:

(a) Source ID 032A - 0.06 lb/hr

(b) Source ID 035A - 0.05 lb/hr

[Additional authority for this permit condition is derived from PAs 22-05012A & 22-05012B]

004 [25 Pa. Code §127.512]**Operating permit terms and conditions.**

(a) NO_x emissions from Source IDs 032A and 035A shall not exceed 30 ppm on natural gas, dry basis and corrected to three percent oxygen (equivalent to: 3.55 lb/hr for Source ID 032A).

(b) CO emission from Source IDs 032A and 035A shall not exceed 70 ppm on natural gas, dry basis corrected to three percent oxygen (equivalent to 5.08 lb/hr for Source ID 032A).

[Additional authority for this permit condition is derived from PAs 22-05012A & 22-05012B]

**SECTION E. Source Group Restrictions.****# 005 [25 Pa. Code §127.512]****Operating permit terms and conditions.**

Particulate matter emissions shall not exceed the following when combusting natural gas:

- (a) Source ID 032A - 0.5 lb/hr
- (b) Source ID 035A - 0.3 lb/hr

[Additional authority for this permit condition is derived from PAs 22-05012A & 22-05012B]

Fuel Restriction(s).**# 006 [25 Pa. Code §123.22]****Combustion units**

(a) The permittee may not offer for sale, deliver for use, exchange in trade or permit the use commercial fuel oil in an air basin, which contain sulfur in excess of:

- (1) No. 2 - 500 ppm (0.05% by weight)

(b) Beginning September 1, 2020, the sulfur content of commercial fuel oil shall not exceed:

- (1) No. 2 - 15 ppm (0.0015% by weight)

(c) Commercial fuel oil that was stored in this Commonwealth by the ultimate consumer prior to September 1, 2020, which met the applicable maximum allowable sulfur content for commercial fuel oil through August 31, 2020, in subparagraph (i) at the time it was stored, may be used by the ultimate consumer in this Commonwealth on and after September 1, 2020.

(d) Beginning July 1, 2016, the Department may temporarily suspend or increase the applicable maximum allowable sulfur content for a commercial fuel oil set forth in subparagraph (a) if the following occur:

(1) The Department receives a written request at the address specified in subsection 25 Pa Code 123.22(h) for a suspension or increase on the basis that compliant commercial fuel oil is not reasonably available in a nonair basin area. The request must include the following:

- (i) The nonair basin county or counties for which the suspension or increase is requested.
- (ii) The reason compliant commercial fuel oil is not reasonably available.
- (iii) The duration of time for which the suspension or increase is requested and the justification for the requested duration.

(2) The Department determines that an insufficient quantity of compliant commercial fuel oil is reasonably available in the nonair basin area and that the circumstances leading to the insufficiency are due to events that could not have been reasonably foreseen or prevented and are not due to lack of prudent planning on the part of the transferor of the commercial fuel oil into or within the specified nonair basin area.

(3) The Department approves the request, in writing, prior to the transferor distributing the noncompliant commercial fuel oil into or within the specified nonair basin area.

(e) The Department will limit a suspension or increase in the applicable maximum allowable sulfur content granted under subparagraph (d) to the shortest duration in which adequate supplies of compliant commercial fuel oil can be made reasonably available, but in no case longer than 60 days from the date the Department grants the suspension or increase.

**SECTION E. Source Group Restrictions.****Throughput Restriction(s).****# 007 [25 Pa. Code §127.441]****Operating permit terms and conditions.**

(a) The permittee shall limit the combustion of #2 fuel oil to the following:

- (1) Source ID 032A - 110,000 gallons in any consecutive 12-month period.
- (2) Source ID 035A - 31,000 gallons in any consecutive 12-month period.

(b) Compliance verification requires fuel use be monitored and recorded for each month and each consecutive 12-month period.

II. TESTING REQUIREMENTS.**# 008 [25 Pa. Code §127.512]****Operating permit terms and conditions.**

(a) Unless otherwise approved in writing by DEP, the permittee shall conduct stack test of the Source ID 032A to verify the emissions, once during the term of the permit (prior to expiration of this permit). Unless otherwise approved in writing by DEP, the performance test shall be conducted while the unit is operating at maximum routine operating conditions or under such other conditions, within the capacity of the equipment, as may be requested by the Department. The testing shall include the following pollutants:

- (1) Nitrogen Oxides (NO_x) expressed as NO₂
- (2) Carbon Monoxide (CO)

(b) The test protocol must include conditions at which each boiler will be operated during the performance testing

(c) Stack testing and reporting shall comply with Section C, Condition #009.

(d) The measured 3-run CO₂ and O₂ readings, the gas flow, and temperature parameters shall be included in the test report.

[Additional authority for this permit condition is derived from PAs 22-05012A & 22-05012B]

III. MONITORING REQUIREMENTS.

No additional monitoring requirements exist except as provided in other sections of this permit including Section B (Title V General Requirements).

IV. RECORDKEEPING REQUIREMENTS.

No additional record keeping requirements exist except as provided in other sections of this permit including Section B (Title V General Requirements).

V. REPORTING REQUIREMENTS.

No additional reporting requirements exist except as provided in other sections of this permit including Section B (Title V General Requirements).

VI. WORK PRACTICE REQUIREMENTS.

No additional work practice requirements exist except as provided in other sections of this permit including Section B (Title V General Requirements).

VII. ADDITIONAL REQUIREMENTS.**# 009 [25 Pa. Code §127.441]****Operating permit terms and conditions.**

Each above boiler is exempt from 40 CFR Part 63, Subpart JJJJJJ, if it meets the following criteria: only combusts natural gas not combined with any solid fuels and burns liquid fuel only during periods of gas curtailment, gas supply interruption,

**SECTION E. Source Group Restrictions.**

startups, or periodic testing on liquid fuel. Periodic testing of liquid fuel shall not exceed a combined total of 48 hours during any calendar year.

***** Permit Shield in Effect. *****

**SECTION E. Source Group Restrictions.**

Group Name: 09

Group Description: 40 CFR 63, Subpart YYYYY Source(s)

Sources included in this group

ID	Name
501A	#207 DCEAF
501B	LADLE REFINING FURNACE

I. RESTRICTIONS.

No additional requirements exist except as provided in other sections of this permit including Section B (Title V General Requirements).

II. TESTING REQUIREMENTS.

No additional testing requirements exist except as provided in other sections of this permit including Section B (Title V General Requirements).

III. MONITORING REQUIREMENTS.

No additional monitoring requirements exist except as provided in other sections of this permit including Section B (Title V General Requirements).

IV. RECORDKEEPING REQUIREMENTS.

No additional record keeping requirements exist except as provided in other sections of this permit including Section B (Title V General Requirements).

V. REPORTING REQUIREMENTS.

No additional reporting requirements exist except as provided in other sections of this permit including Section B (Title V General Requirements).

VI. WORK PRACTICE REQUIREMENTS.

No additional work practice requirements exist except as provided in other sections of this permit including Section B (Title V General Requirements).

VII. ADDITIONAL REQUIREMENTS.**# 001 [25 Pa. Code §127.441]****Operating permit terms and conditions.****Regulatory Changes**

Individual sources within this source group that are subject to 40 CFR Part 63, Subpart YYYYY - National Emission Standards for Hazardous Air Pollutants for Area Sources: Electric Arc Furnace Steelmaking Facilities shall comply with all applicable requirements of the Subpart. 40 CFR 63.13(a) requires submission of copies of all requests, reports and other communications to both the Department and the EPA. The EPA copies shall be forwarded to:

Associate Director
 United States Environmental Protection Agency
 Region III, Enforcement & Compliance Assurance Division
 Air, RCRA and Toxics Branch (3ED21)
 Four Penn Center
 1600 John F. Kennedy Boulevard
 Philadelphia, Pennsylvania 19103-2852

The Department copies shall be forwarded to the DEP SCRO Air Quality Program Manager at wiveaver@pa.gov, unless otherwise directed in writing by DEP.

In the event that the Federal Subpart that is the subject of this Source Group is revised, the permittee shall comply with the

**SECTION E. Source Group Restrictions.**

revised version of the subpart, and shall not be required to comply with any provisions in this permit designated as having the subpart as their authority, to the extent that such permit provisions would be inconsistent with the applicable provisions of the revised subpart.

002 [40 CFR Part 63 NESHAPS for Source Categories §40 CFR 63.10680]**Subpart YYYYY - National Emission Standards for Hazardous Air Pollutants for Area Sources: Electric Arc Furnace Steelmaking Facilities****Am I subject to this subpart?**

63.10680(a) You are subject to this subpart if you own or operate an electric arc furnace (EAF) steelmaking facility that is an area source of hazardous air pollutant (HAP) emissions.

63.10680(b) This subpart applies to each new or existing affected source. The affected source is each EAF steelmaking facility.

63.10680(b)(1) An affected source is existing if you commenced construction or reconstruction of the affected source on or before September 20, 2007.

63.10680(b)(2) An affected source is new if you commenced construction or reconstruction of the affected source after September 20, 2007.

63.10680(c) This subpart does not apply to research and development facilities, as defined in section 112(c)(7) of the Clean Air Act (CAA).

63.10680(d) If you own or operate an area source subject to this subpart, you must have or obtain a permit under 40 CFR part 70 or 40 CFR part 71.

003 [40 CFR Part 63 NESHAPS for Source Categories §40 CFR 63.10681]**Subpart YYYYY - National Emission Standards for Hazardous Air Pollutants for Area Sources: Electric Arc Furnace Steelmaking Facilities****What are my compliance dates?**

63.10681(a) Except as provided in paragraph (b) of this section, if you own or operate an existing affected source, you must achieve compliance with the applicable provisions of this subpart by no later than June 30, 2008. [COMPLIANCE DEMONSTRATED BY DEADLINE]

63.10681(b) If you own or operate an existing affected source, you must achieve compliance with opacity limit in § 63.10686(b)(2) or (c)(2) by no later than December 28, 2010 if you demonstrate to the satisfaction of the permitting authority that additional time is needed to install or modify emission control equipment. [OPACITY COMPLIANCE ALREADY DEMONSTRATED BY DEADLINE]

63.10681(c) - (d) [NA - EXISTING SOURCE]

004 [40 CFR Part 63 NESHAPS for Source Categories §40 CFR 63.10685]**Subpart YYYYY - National Emission Standards for Hazardous Air Pollutants for Area Sources: Electric Arc Furnace Steelmaking Facilities****What are the requirements for the control of contaminants from scrap?**

63.10685(a) Chlorinated plastics, lead, and free organic liquids.

For metallic scrap utilized in the EAF at your facility, you must comply with the requirements in either paragraph (a)(1) or (2) of this section. You may have certain scrap at your facility subject to paragraph (a)(1) of this section and other scrap subject to paragraph (a)(2) of this section provided the scrap remains segregated until charge make-up.

63.10685(a)(1) Pollution prevention plan.

For the production of steel other than leaded steel, you must prepare and implement a pollution prevention plan for metallic scrap selection and inspection to minimize the amount of chlorinated plastics, lead, and free organic liquids that is charged to the furnace. For the production of leaded steel, you must prepare and implement a pollution prevention plan for scrap selection and inspection to minimize the amount of chlorinated plastics and free organic liquids in the scrap that is charged to the furnace. You must submit the scrap pollution prevention plan to the permitting authority for approval. You must

**SECTION E. Source Group Restrictions.**

operate according to the plan as submitted during the review and approval process, operate according to the approved plan at all times after approval, and address any deficiency identified by the permitting authority within 60 days following disapproval of a plan. You may request approval to revise the plan and may operate according to the revised plan unless and until the revision is disapproved by the permitting authority. You must keep a copy of the plan onsite, and you must provide training on the plan's requirements to all plant personnel with materials acquisition or inspection duties. Each plan must include the information in paragraphs (a)(1)(i) through (iii) of this section:

63.10685(a)(1)(i) Specifications that scrap materials must be depleted (to the extent practicable) of undrained used oil filters, chlorinated plastics, and free organic liquids at the time of charging to the furnace.

63.10685(a)(1)(ii) A requirement in your scrap specifications for removal (to the extent practicable) of lead-containing components (such as batteries, battery cables, and wheel weights) from the scrap, except for scrap used to produce leaded steel.

63.10685(a)(1)(iii) Procedures for determining if the requirements and specifications in paragraph (a)(1) of this section are met (such as visual inspection or periodic audits of scrap providers) and procedures for taking corrective actions with vendors whose shipments are not within specifications.

63.10685(a)(1)(iv) The requirements of paragraph (a)(1) of this section do not apply to the routine recycling of baghouse bags or other internal process or maintenance materials in the furnace. These exempted materials must be identified in the pollution prevention plan.

63.10685(a)(2) Restricted metallic scrap.

For the production of steel other than leaded steel, you must not charge to a furnace metallic scrap that contains scrap from motor vehicle bodies, engine blocks, oil filters, oily turnings, machine shop borings, transformers or capacitors containing polychlorinated biphenyls, lead-containing components, chlorinated plastics, or free organic liquids. For the production of leaded steel, you must not charge to the furnace metallic scrap that contains scrap from motor vehicle bodies, engine blocks, oil filters, oily turnings, machine shop borings, transformers or capacitors containing polychlorinated biphenyls, chlorinated plastics, or free organic liquids. This restriction does not apply to any post-consumer engine blocks, post-consumer oil filters, or oily turnings that are processed or cleaned to the extent practicable such that the materials do not include lead components, chlorinated plastics, or free organic liquids. This restriction does not apply to motor vehicle scrap that is charged to recover the chromium or nickel content if you meet the requirements in paragraph (b)(3) of this section.

63.10685(b) Mercury requirements.

For scrap containing motor vehicle scrap, you must procure the scrap pursuant to one of the compliance options in paragraphs (b)(1), (2), or (3) of this section for each scrap provider, contract, or shipment. For scrap that does not contain motor vehicle scrap, you must procure the scrap pursuant to the requirements in paragraph (b)(4) of this section for each scrap provider, contract, or shipment. You may have one scrap provider, contract, or shipment subject to one compliance provision and others subject to another compliance provision.

63.10685(b)(1) Site-specific plan for mercury switches.

You must comply with the requirements in paragraphs (b)(1)(i) through (v) of this section.

63.10685(b)(1)(i) You must include a requirement in your scrap specifications for removal of mercury switches from vehicle bodies used to make the scrap.

63.10685(b)(1)(ii) You must prepare and operate according to a plan demonstrating how your facility will implement the scrap specification in paragraph (b)(1)(i) of this section for removal of mercury switches. You must submit the plan to the permitting authority for approval. You must operate according to this plan as submitted during the review and approval process, operate according to the approved plan at all times after approval, and address any deficiency identified by the permitting authority within 60 days following disapproval of a plan. You may request approval to revise the plan and may operate according to the revised plan unless and until the revision is disapproved by the permitting authority. The permitting authority may change the approval status of the plan upon 90-days written notice based upon the semiannual compliance report or other information. The plan must include:

**SECTION E. Source Group Restrictions.**

63.10685(b)(1)(ii)(A) A means of communicating to scrap purchasers and scrap providers the need to obtain or provide motor vehicle scrap from which mercury switches have been removed and the need to ensure the proper management of the mercury switches removed from that scrap as required under the rules implementing subtitle C of the Resource Conservation and Recovery Act (RCRA) (40 CFR parts 261 through 265 and 268). The plan must include documentation of direction to appropriate staff to communicate to suppliers throughout the scrap supply chain the need to promote the removal of mercury switches from end-of-life vehicles. Upon the request of the permitting authority, you must provide examples of materials that are used for outreach to suppliers, such as letters, contract language, policies for purchasing agents, and scrap inspection protocols;

63.10685(b)(1)(ii)(B) Provisions for obtaining assurance from scrap providers that motor vehicle scrap provided to the facility meet the scrap specification;

63.10685(b)(1)(ii)(C) Provisions for periodic inspections or other means of corroboration to ensure that scrap providers and dismantlers are implementing appropriate steps to minimize the presence of mercury switches in motor vehicle scrap and that the mercury switches removed are being properly managed, including the minimum frequency such means of corroboration will be implemented; and

63.10685(b)(1)(ii)(D) Provisions for taking corrective actions (i.e., actions resulting in scrap providers removing a higher percentage of mercury switches or other mercury-containing components) if needed, based on the results of procedures implemented in paragraph (b)(1)(ii)(C) of this section).

63.10685(b)(1)(iii) You must require each motor vehicle scrap provider to provide an estimate of the number of mercury switches removed from motor vehicle scrap sent to your facility during the previous year and the basis for the estimate. The permitting authority may request documentation or additional information at any time.

63.10685(b)(1)(iv) You must establish a goal for each scrap provider to remove at least 80 percent of the mercury switches. Although a site-specific plan approved under paragraph (b)(1) of this section may require only the removal of convenience light switch mechanisms, the permitting authority will credit all documented and verifiable mercury-containing components removed from motor vehicle scrap (such as sensors in anti-locking brake systems, security systems, active ride control, and other applications) when evaluating progress towards the 80 percent goal.

63.10685(b)(1)(v) For each scrap provider, you must submit semiannual progress reports to the permitting authority that provide the number of mercury switches removed or the weight of mercury recovered from the switches, the estimated number of vehicles processed, an estimate of the percent of mercury switches removed, and certification that the removed mercury switches were recycled at RCRA-permitted facilities or otherwise properly managed pursuant to RCRA subtitle C regulations referenced in paragraph (b)(1)(ii)(A) of this section. This information can be submitted in aggregated form and does not have to be submitted for each scrap provider, contract, or shipment. The permitting authority may change the approval status of a site-specific plan following 90-days notice based on the progress reports or other information.

63.10685(b)(2) Option for approved mercury programs.

You must certify in your notification of compliance status that you participate in and purchase motor vehicle scrap only from scrap providers who participate in a program for removal of mercury switches that has been approved by the Administrator based on the criteria in paragraphs (b)(2)(i) through (iii) of this section. If you purchase motor vehicle scrap from a broker, you must certify that all scrap received from that broker was obtained from other scrap providers who participate in a program for the removal of mercury switches that has been approved by the Administrator based on the criteria in paragraphs (b)(2)(i) through (iii) of this section. The National Vehicle Mercury Switch Recovery Program and the Vehicle Switch Recovery Program mandated by Maine State law are EPA-approved programs under paragraph (b)(2) of this section unless and until the Administrator disapproves the program (in part or in whole) under paragraph (b)(2)(iii) of this section.

63.10685(b)(2)(i) The program includes outreach that informs the dismantlers of the need for removal of mercury switches and provides training and guidance for removing mercury switches;

63.10685(b)(2)(ii) The program has a goal to remove at least 80 percent of mercury switches from the motor vehicle scrap the scrap provider processes. Although a program approved under paragraph (b)(2) of this section may require only the removal of convenience light switch mechanisms, the Administrator will credit all documented and verifiable mercury-

**SECTION E. Source Group Restrictions.**

containing components removed from motor vehicle scrap (such as sensors in anti-locking brake systems, security systems, active ride control, and other applications) when evaluating progress towards the 80 percent goal; and

63.10685(b)(2)(iii) The program sponsor agrees to submit progress reports to the Administrator no less frequently than once every year that provide the number of mercury switches removed or the weight of mercury recovered from the switches, the estimated number of vehicles processed, an estimate of the percent of mercury switches recovered, and certification that the recovered mercury switches were recycled at facilities with permits as required under the rules implementing subtitle C of RCRA (40 CFR parts 261 through 265 and 268). The progress reports must be based on a database that includes data for each program participant; however, data may be aggregated at the State level for progress reports that will be publicly available. The Administrator may change the approval status of a program or portion of a program (e.g., at the State level) following 90-days notice based on the progress reports or on other information.

63.10685(b)(2)(iv) You must develop and maintain onsite a plan demonstrating the manner through which your facility is participating in the EPA-approved program.

63.10685(b)(2)(iv)(A) The plan must include facility-specific implementation elements, corporate-wide policies, and/or efforts coordinated by a trade association as appropriate for each facility.

63.10685(b)(2)(iv)(B) You must provide in the plan documentation of direction to appropriate staff to communicate to suppliers throughout the scrap supply chain the need to promote the removal of mercury switches from end-of-life vehicles. Upon the request of the permitting authority, you must provide examples of materials that are used for outreach to suppliers, such as letters, contract language, policies for purchasing agents, and scrap inspection protocols.

63.10685(b)(2)(iv)(C) You must conduct periodic inspections or provide other means of corroboration to ensure that scrap providers are aware of the need for and are implementing appropriate steps to minimize the presence of mercury in scrap from end-of-life vehicles.

63.10685(b)(3) Option for specialty metal scrap.

You must certify in your notification of compliance status that the only materials from motor vehicles in the scrap are materials recovered for their specialty alloy (including, but not limited to, chromium, nickel, molybdenum, or other alloys) content (such as certain exhaust systems) and, based on the nature of the scrap and purchase specifications, that the type of scrap is not reasonably expected to contain mercury switches.

63.10685(b)(4) Scrap that does not contain motor vehicle scrap.

For scrap not subject to the requirements in paragraphs (b)(1) through (3) of this section, you must certify in your notification of compliance status and maintain records of documentation that this scrap does not contain motor vehicle scrap.

63.10685(c) Recordkeeping and reporting requirements.

In addition to the records required by § 63.10, you must keep records to demonstrate compliance with the requirements for your pollution prevention plan in paragraph (a)(1) of this section and/or for the use of only restricted scrap in paragraph (a)(2) of this section and for mercury in paragraphs (b)(1) through (3) of this section as applicable. You must keep records documenting compliance with paragraph (b)(4) of this section for scrap that does not contain motor vehicle scrap.

63.10685(c)(1) If you are subject to the requirements for a site-specific plan for mercury under paragraph (b)(1) of this section, you must:

63.10685(c)(1)(i) Maintain records of the number of mercury switches removed or the weight of mercury recovered from the switches and properly managed, the estimated number of vehicles processed, and an estimate of the percent of mercury switches recovered; and

63.10685(c)(1)(ii) Submit semiannual reports of the number of mercury switches removed or the weight of mercury recovered from the switches and properly managed, the estimated number of vehicles processed, an estimate of the percent of mercury switches recovered, and a certification that the recovered mercury switches were recycled at RCRA-permitted facilities. The semiannual reports must include a certification that you have conducted inspections or taken other

**SECTION E. Source Group Restrictions.**

means of corroboration as required under paragraph (b)(1)(ii)(C) of this section. You may include this information in the semiannual compliance reports required under paragraph (c)(3) of this section.

63.10685(c)(2) If you are subject to the option for approved mercury programs under paragraph (b)(2) of this section, you must maintain records identifying each scrap provider and documenting the scrap provider's participation in an approved mercury switch removal program. If you purchase motor vehicle scrap from a broker, you must maintain records identifying each broker and documentation that all scrap provided by the broker was obtained from other scrap providers who participate in an approved mercury switch removal program.

63.10685(c)(3) You must submit semiannual compliance reports to the Administrator for the control of contaminants from scrap according to the requirements in § 63.10(e). The report must clearly identify any deviation from the requirements in paragraphs (a) and (b) of this section and the corrective action taken. You must identify which compliance option in paragraph (b) of this section applies to each scrap provider, contract, or shipment.

005 [40 CFR Part 63 NESHAPS for Source Categories §40 CFR 63.10686]**Subpart YYYYY - National Emission Standards for Hazardous Air Pollutants for Area Sources: Electric Arc Furnace Steelmaking Facilities****What are the requirements for electric arc furnaces and argon-oxygen decarburization vessels?**

63.10686(a) You must install, operate, and maintain a capture system that collects the emissions from each EAF (including charging, melting, and tapping operations) and argon-oxygen decarburization (AOD) vessel and conveys the collected emissions to a control device for the removal of particulate matter (PM).

63.10686(b) Except as provided in paragraph (c) of this section, you must not discharge or cause the discharge into the atmosphere from an EAF or AOD vessel any gases which:

63.10686(b)(1) Exit from a control device and contain in excess of 0.0052 grains of PM per dry standard cubic foot (gr/dscf); and

63.10686(b)(2) Exit from a melt shop and, due solely to the operations of any affected EAF(s) or AOD vessel(s), exhibit 6 percent opacity or greater.

63.10686(c) [NA - DOES NOT HAVE A CAPACITY OF LESS THAN 150,000 TPY OF STAINLESS STEEL OR SPECIALTY STEEL]

63.10686(d) Except as provided in paragraph (d)(6) of this section, you must conduct performance tests to demonstrate initial compliance with the applicable emissions limit for each emissions source subject to an emissions limit in paragraph (b) or (c) of this section.

63.10686(d)(1) You must conduct each PM performance test for an EAF or AOD vessel according to the procedures in § 63.7 and 40 CFR 60.275a using the following test methods in 40 CFR part 60, appendices A-1, A-2, A-3, and A-4:

63.10686(d)(1)(i) Method 1 or 1A of appendix A-1 of 40 CFR part 60 to select sampling port locations and the number of traverse points in each stack or duct. Sampling sites must be located at the outlet of the control device (or at the outlet of the emissions source if no control device is present) prior to any releases to the atmosphere.

63.10686(d)(1)(ii) Method 2, 2A, 2C, 2D, 2F, or 2G of appendix A-1 of 40 CFR part 60 to determine the volumetric flow rate of the stack gas.

63.10686(d)(1)(iii) Method 3, 3A, or 3B of appendix A-3 of 40 CFR part 60 to determine the dry molecular weight of the stack gas. You may use ANSI/ASME PTC 19.10-1981, "Flue and Exhaust Gas Analyses" (incorporated by reference—see § 63.14) as an alternative to EPA Method 3B.

63.10686(d)(1)(iv) Method 4 of appendix A-3 of 40 CFR part 60 to determine the moisture content of the stack gas.

63.10686(d)(1)(v) Method 5 or 5D of appendix A-3 of 40 CFR part 60 to determine the PM concentration. Three valid test runs are needed to comprise a PM performance test. For EAF, sample only when metal is being melted and refined. For AOD vessels, sample only when the operation(s) are being conducted.

**SECTION E. Source Group Restrictions.**

63.10686(d)(2) You must conduct each opacity test for a melt shop according to the procedures in § 63.6(h) and Method 9 of appendix A-4 of 40 CFR part 60. When emissions from any EAF or AOD vessel are combined with emissions from emission sources not subject to this subpart, you must demonstrate compliance with the melt shop opacity limit based on emissions from only the emission sources subject to this subpart.

63.10686(d)(3) During any performance test, you must monitor and record the information specified in 40 CFR 60.274a(h) for all heats covered by the test.

63.10686(d)(4) You must notify and receive approval from the Administrator for procedures that will be used to determine compliance for an EAF or AOD vessel when emissions are combined with those from facilities not subject to this subpart.

63.10686(d)(5) To determine compliance with the PM emissions limit in paragraph (c) of this section for an EAF or AOD vessel in a lb/ton of steel format, compute the process-weighted mass emissions (E_p) for each test run using Equation 1 of this section:

$$E_p = (C \times Q \times T) / (P \times K)$$

Where:

E_p = Process-weighted mass emissions of PM, lb/ton;

C = Concentration of PM or total metal HAP, gr/dscf;

Q = Volumetric flow rate of stack gas, dscf/hr;

T = Total time during a test run that a sample is withdrawn from the stack during steel production cycle, hr;

P = Total amount of metal produced during the test run, tons; and

K = Conversion factor, 7,000 grains per pound.

63.10686(d)(6) If you own or operate an existing affected source that is subject to the emissions limits in paragraph (b) or (c) of this section, you may certify initial compliance with the applicable emission limit for one or more emissions sources based on the results of a previous performance test for that emissions source in lieu of the requirement for an initial performance test provided that the test(s) were conducted within 5 years of the compliance date using the methods and procedures specified in paragraph (d)(1) or (2) of this section; the test(s) were for the affected facility; and the test(s) were representative of current or anticipated operating processes and conditions. Should the permitting authority deem the prior test data unacceptable to demonstrate compliance with an applicable emissions limit, the owner or operator must conduct an initial performance test within 180 days of the compliance date or within 90 days of receipt of the notification of disapproval of the prior test, whichever is later.

63.10686(e) You must monitor the capture system and PM control device required by this subpart, maintain records, and submit reports according to the compliance assurance monitoring requirements in 40 CFR part 64. The exemption in 40 CFR 64.2(b)(1)(i) for emissions limitations or standards proposed after November 15, 1990 under section 111 or 112 of the CAA does not apply. In lieu of the deadlines for submittal in 40 CFR 64.5, you must submit the monitoring information required by 40 CFR 64.4 to the applicable permitting authority for approval by no later than the compliance date for your affected source for this subpart and operate according to the approved plan by no later than 180 days after the date of approval by the permitting authority.

006 [40 CFR Part 63 NESHAPS for Source Categories §40 CFR 63.10690]

Subpart YYYYY - National Emission Standards for Hazardous Air Pollutants for Area Sources: Electric Arc Furnace Steelmaking Facilities

What parts of the General Provisions apply to this subpart?

63.10690(a) You must comply with the requirements of the NESHAP General Provisions (40 CFR part 63, subpart A) as provided in Table 1 of this subpart.

63.10690(b) The notification of compliance status required by § 63.9(h) must include each applicable certification of compliance, signed by a responsible official, in paragraphs (b)(1) through (6) of this section.

63.10690(b)(1) For the pollution prevention plan requirements in § 63.10685(a)(1): "This facility has submitted a pollution prevention plan for metallic scrap selection and inspection in accordance with § 63.10685(a)(1)";

**SECTION E. Source Group Restrictions.**

63.10690(b)(2) For the restrictions on metallic scrap in § 63.10685(a)(2): "This facility complies with the requirements for restricted metallic scrap in accordance with § 63.10685(a)(2)";

63.10690(b)(3) For the mercury requirements in § 63.10685(b):

63.10690(b)(3)(i) "This facility has prepared a site-specific plan for mercury switches in accordance with § 63.10685(b)(1)";

63.10690(b)(3)(ii) "This facility participates in and purchases motor vehicle scrap only from scrap providers who participate in a program for removal of mercury switches that has been approved by the EPA Administrator in accordance with § 63.10685(b)(2)" and has prepared a plan demonstrating how the facility participates in the EPA-approved program in accordance with § 63.10685(b)(2)(iv);

63.10690(b)(3)(iii) "The only materials from motor vehicles in the scrap charged to an electric arc furnace at this facility are materials recovered for their specialty alloy content in accordance with § 63.10685(b)(3) which are not reasonably expected to contain mercury switches"; or

63.10690(b)(3)(iv) "This facility complies with the requirements for scrap that does not contain motor vehicle scrap in accordance with § 63.10685(b)(4)."

63.10690(b)(4) This certification of compliance for the capture system requirements in § 63.10686(a), signed by a responsible official: "This facility operates a capture system for each electric arc furnace and argon-oxygen decarburization vessel that conveys the collected emissions to a PM control device in accordance with § 63.10686(a)".

63.10690(b)(5) If applicable, this certification of compliance for the performance test requirements in § 63.10686(d)(6): "This facility certifies initial compliance with the applicable emissions limit in § 63.10686(a) or (b) based on the results of a previous performance test in accordance with § 63.10686(d)(6)".

63.10690(b)(6) This certification of compliance for the monitoring requirements in § 63.10686(e), signed by a responsible official: "This facility has developed and submitted proposed monitoring information in accordance with 40 CFR part 64".

007 [40 CFR Part 63 NESHAPS for Source Categories §40 CFR 63.10691]

Subpart YYYYY - National Emission Standards for Hazardous Air Pollutants for Area Sources: Electric Arc Furnace Steelmaking Facilities

Who implements and enforces this subpart?

63.10691(a) This subpart can be implemented and enforced by the EPA or a delegated authority such as a State, local, or tribal agency. If the EPA Administrator has delegated authority to a State, local, or tribal agency, then that Agency has the authority to implement and enforce this subpart. You should contact your EPA Regional Office to find out if this subpart is delegated to your State, local, or tribal agency.

63.10691(b) In delegating implementation and enforcement authority of this subpart to a State, local, or tribal agency under 40 CFR part 63, subpart E, the authorities contained in paragraph (c) of this section are retained by the Administrator and are not transferred to the State, local, or tribal agency.

63.10691(c) The authorities that will not be delegated to State, local, or tribal agencies are listed in paragraphs (c)(1) through (6) of this section.

63.10691(c)(1) Approval of an alternative non-opacity emissions standard under 40 CFR 63.6(g).

63.10691(c)(2) Approval of an alternative opacity emissions standard under § 63.6(h)(9).

63.10691(c)(3) Approval of a major change to test methods under § 63.7(e)(2)(ii) and (f). A "major change to test method" is defined in 40 CFR 63.90.

63.10691(c)(4) Approval of major change to monitoring under 40 CFR 63.8(f). A "major change to monitoring" is defined in 40 CFR 63.90.

**SECTION E. Source Group Restrictions.**

63.10691(c)(5) Approval of a major change to recordkeeping/reporting under 40 CFR 63.10(f). A "major change to recordkeeping/reporting" is defined in 40 CFR 63.90.

63.10691(c)(6) Approval of a program for the removal of mercury switches under § 63.10685(b)(2).

***** Permit Shield in Effect. *****

**SECTION E. Source Group Restrictions.**

Group Name: 10

Group Description: CEMS, DCEAF & LRF

Sources included in this group

ID	Name
501A	#207 DCEAF
501B	LADLE REFINING FURNACE

I. RESTRICTIONS.

No additional requirements exist except as provided in other sections of this permit including Section B (Title V General Requirements).

II. TESTING REQUIREMENTS.

No additional testing requirements exist except as provided in other sections of this permit including Section B (Title V General Requirements).

III. MONITORING REQUIREMENTS.**# 001 [25 Pa. Code §127.411]****Content of applications.**

All continuous emission monitors shall meet the following minimum data availability requirements:

(a) In accordance with 25 PA Code §139.101(12), required monitoring for NO_x and CO shall, at a minimum, meet one of the following data availability requirements unless otherwise stipulated in this permit, plan approval, Title 25 or an order issued under Section 4 of the Air Pollution Control Act:

(1) In each calendar month, at least 90% of the time periods for which each emission standard applies, shall be valid as set forth in the Quality Assurance section of Revision No. 8 of the Department's Continuous Source Monitoring Manual or;

(2) In each calendar quarter, at least 95% of the hours shall be valid as set forth in the Quality Assurance section of Revision No. 8 of the Department's Continuous Source Monitoring Manual.

Compliance with any subsequently issued revisions to the Continuous Source Manual will constitute compliance with this condition.

IV. RECORDKEEPING REQUIREMENTS.**# 002 [25 Pa. Code §127.411]****Content of applications.**

The permittee shall comply with the recordkeeping requirements established in 25 Pa. Code Chapter 139, Subchapter C (relating to requirements for source monitoring for stationary sources), (and) the "Record Keeping and Reporting" requirements in Revision No. 8 of the Department's Continuous Source Monitoring Manual, 274-0300-001.

Records shall be retained for at least 5 years and shall be made available to the Department upon request.

Compliance with any subsequently issued revision to the Continuous Source Monitoring Manual will constitute compliance with this permit condition.

V. REPORTING REQUIREMENTS.**# 003 [25 Pa. Code §127.411]****Content of applications.**

The permittee shall submit quarterly reports of continuous emission monitoring to the Department in accordance with the requirements established in 25 Pa. Code Chapter 139, Subchapter C (relating to requirements for source monitoring for stationary sources), and the Record Keeping and Reporting requirements as established in Revision No. 8 of the Department's Continuous Source Monitoring Manual, 274-0300-001, and; the permittee shall report emissions for all periods of unit operation, including startup, shutdown and malfunction.

Initial quarterly reports following system certification shall be submitted to the Department by the deadline established in the CEMS certification letter.

**SECTION E. Source Group Restrictions.**

Subsequent quarterly reports shall be submitted to the Department within 30 days after the end of each calendar quarter.

Failure to submit required reports of continuous emission monitoring within the time periods specified in this Condition, shall constitute violations of this Permit, unless approved in advance by the Department in writing.

Compliance with any subsequently issued revision to the Continuous Source Monitoring Manual will constitute compliance with this permit condition.

VI. WORK PRACTICE REQUIREMENTS.**# 004 [25 Pa. Code §127.411]****Content of applications.**

Quality Assurance Requirement:

Continuous Emission Monitoring Systems and components must be operated and maintained in accordance with the requirements established in 25 PA Code Chapter 139, Subchapter C (relating to requirements for source monitoring for stationary sources) and the "Quality Assurance" requirements in the Department's Continuous Source Monitoring Manual, Revision No. 8.

Compliance with any subsequently issued revision to the Continuous Source Monitoring Manual will constitute compliance with this permit condition.

[Additional authority for this permit condition is derived from 25 PA Code §§ 139.101(1)(v), 139.101(2), 139.101(3), 139.101(4), 139.101(6), 139.101(7), 139.101(12), 139.(14) and 139.101(15)]

VII. ADDITIONAL REQUIREMENTS.**# 005 [25 Pa. Code §127.411]****Content of applications.**

The following continuous emission monitoring system (CEMS) and components must be installed, approved by the Department, operated and maintained in accordance with the requirements of 25 Pa. Code Chapter 139, Subchapter C (relating to requirements for source monitoring for stationary sources), and the Submittal and Approval, Record Keeping and Reporting, and Quality Assurance requirements of Revision No. 8 of the Department's Continuous Source Monitoring Manual, 274-0300-001.

FURNACE**1. NO_x CEMS 1**

- a. Source Combination to be Monitored: Source 501A & 501B
- b. Parameter to be Reported: NO_x
- c. Units of Measurement to be Reported: lb/hr
- d. Moisture Basis of Measurement to be Reported: NA
- e. Correction basis of Measurements to be Reported: NA
- f. Data Substitution Required: No
- g. Emission Standard: NA
- h. Averaging Period: 1-hour average, block

2. NO_x CEMS 2

- a. Source Combination to be Monitored: Source 501A & 501B
- b. Parameter to be Reported: NO_x
- c. Units of Measurement to be Reported: lb/hr
- d. Moisture Basis of Measurement to be Reported: NA
- e. Correction basis of Measurements to be Reported: NA
- f. Data Substitution Required: No
- g. Emission Standard: 26.1 lb/hr
- h. Averaging Period: 1-day average, block

3. CO CEMS 1

- a. Source Combination to be Monitored: Source 501A & 501B

**SECTION E. Source Group Restrictions.**

- b. Parameter to be Reported: NOx
- c. Units of Measurement to be Reported: lb/hr
- d. Moisture Basis of Measurement to be Reported: NA
- e. Correction basis of Measurements to be Reported: NA
- f. Data Substitution Required: No
- g. Emission Standard: NA
- h. Averaging Period: 1-hour average, block

4. CO CEMS 2

- a. Source Combination to be Monitored: Source 501A & 501B
- b. Parameter to be Reported: CO
- c. Units of Measurement to be Reported: lb/hr
- d. Moisture Basis of Measurement to be Reported: NA
- e. Correction basis of Measurements to be Reported: NA
- f. Data Substitution Required: No
- g. Emission Standard: 251 lb/hr
- h. Averaging Period: 1-day average, block

[NOTE: The above CEMS emissions standards apply during the melt cycle and refining cycle, from start to finish of each cycle]

Compliance with any subsequently issued revisions to the Continuous Source Monitoring Manual will constitute compliance with this condition.

***** Permit Shield in Effect. *****

**SECTION E. Source Group Restrictions.**

Group Name: 11

Group Description: 40 CFR 60, Subpart AAa Source(s)

Sources included in this group

ID	Name
501A #207 DCEAF	
510 #2 BAGHOUSE DUST PNEUMATIC SYSTEM	

I. RESTRICTIONS.

No additional requirements exist except as provided in other sections of this permit including Section B (Title V General Requirements).

II. TESTING REQUIREMENTS.

No additional testing requirements exist except as provided in other sections of this permit including Section B (Title V General Requirements).

III. MONITORING REQUIREMENTS.

No additional monitoring requirements exist except as provided in other sections of this permit including Section B (Title V General Requirements).

IV. RECORDKEEPING REQUIREMENTS.

No additional record keeping requirements exist except as provided in other sections of this permit including Section B (Title V General Requirements).

V. REPORTING REQUIREMENTS.

No additional reporting requirements exist except as provided in other sections of this permit including Section B (Title V General Requirements).

VI. WORK PRACTICE REQUIREMENTS.

No additional work practice requirements exist except as provided in other sections of this permit including Section B (Title V General Requirements).

VII. ADDITIONAL REQUIREMENTS.**# 001 [25 Pa. Code §127.441]****Operating permit terms and conditions.**

Regulatory Changes

Individual sources within this source group that are subject to 40 CFR Part 60, Subpart AAa - Standards of Performance for Steel Plants: Electric Arc Furnaces and Argon-Oxygen Decarburization Vessels Constructed After August 7, 1983 shall comply with all applicable requirements of the Subpart. 40 CFR 60.4(a) requires submission of copies of all requests, reports and other communications to both the Department and the EPA. The EPA copies shall be forwarded to:

Associate Director
 United States Environmental Protection Agency
 Region III, Enforcement & Compliance Assurance Division
 Air, RCRA and Toxics Branch (3ED21)
 Four Penn Center
 1600 John F. Kennedy Boulevard
 Philadelphia, Pennsylvania 19103-2852

The Department copies shall be forwarded to the DEP SCRO Air Quality Program Manager at wiveaver@pa.gov, unless otherwise directed in writing by DEP.

In the event that the Federal Subpart that is the subject of this Source Group is revised, the permittee shall comply with the

**SECTION E. Source Group Restrictions.**

revised version of the subpart, and shall not be required to comply with any provisions in this permit designated as having the subpart as their authority, to the extent that such permit provisions would be inconsistent with the applicable provisions of the revised subpart.

**# 002 [40 CFR Part 60 Standards of Performance for New Stationary Sources §40 CFR 60.270a]
Subpart AAa - Standards of Performance for Steel Plants: Electric Arc Furnaces and Argon-Oxygen Decarburization Vessels Constructed After August 7, 1983
Applicability and designation of affected facility.**

60.270a(a) The provisions of this subpart are applicable to the following affected facilities in steel plants that produce carbon, alloy, or specialty steels: electric arc furnaces, argon-oxygen decarburization vessels, and dust-handling systems.

60.270a(b) The provisions of this subpart apply to each affected facility identified in paragraph (a) of this section that commences construction, modification, or reconstruction after August 17, 1983.

**# 003 [40 CFR Part 60 Standards of Performance for New Stationary Sources §40 CFR 60.272a]
Subpart AAa - Standards of Performance for Steel Plants: Electric Arc Furnaces and Argon-Oxygen Decarburization Vessels Constructed After August 7, 1983
Standard for particulate matter.**

60.272a(a) On and after the date of which the performance test required to be conducted by § 60.8 is completed, no owner or operator subject to the provisions of this subpart shall cause to be discharged into the atmosphere from an EAF or an AOD vessel any gases which:

60.272a(a)(1) Exit from a control device and contain particulate matter in excess of 12 mg/dscm (0.0052 gr/dscf);

60.272a(a)(2) Exit from a control device and exhibit 3 percent opacity or greater; and

60.272a(a)(3) Exit from a shop and, due solely to the operations of any affected EAF(s) or AOD vessel(s), exhibit 6 percent opacity or greater.

60.272a(b) On and after the date on which the performance test required to be conducted by § 60.8 is completed, no owner or operator subject to the provisions of this subpart shall cause to be discharged into the atmosphere from the dust-handling system any gases that exhibit 10 percent opacity or greater.

**# 004 [40 CFR Part 60 Standards of Performance for New Stationary Sources §40 CFR 60.273a]
Subpart AAa - Standards of Performance for Steel Plants: Electric Arc Furnaces and Argon-Oxygen Decarburization Vessels Constructed After August 7, 1983
Emission monitoring.**

60.273a(a) Except as provided under paragraphs (b) and (c) of this section, a continuous monitoring system for the measurement of the opacity of emissions discharged into the atmosphere from the control device(s) shall be installed, calibrated, maintained, and operated by the owner or operator subject to the provisions of this subpart.

60.273a(b) No continuous monitoring system shall be required on any control device serving the dust-handling system.

60.273a(c) A continuous monitoring system for the measurement of the opacity of emissions discharged into the atmosphere from the control device(s) is not required on any modular, multi-stack, negative-pressure or positive-pressure fabric filter if observations of the opacity of the visible emissions from the control device are performed by a certified visible emission observer; or on any single-stack fabric filter if visible emissions from the control device are performed by a certified visible emission observer and the owner installs and continuously operates a bag leak detection system according to paragraph (e) of this section. Visible emission observations shall be conducted at least once per day for at least three 6-minute periods when the furnace is operating in the melting and refining period. All visible emissions observations shall be conducted in accordance with Method 9. If visible emissions occur from more than one point, the opacity shall be recorded for any points where visible emissions are observed. Where it is possible to determine that a number of visible emission sites relate to only one incident of the visible emission, only one set of three 6-minute observations will be required. In that case, the Method 9 observations must be made for the site of highest opacity that directly relates to the cause (or location) of visible emissions observed during a single incident. Records shall be maintained of any 6-minute average that is in excess of the emission limit specified in § 60.272a(a).

60.273a(d) A furnace static pressure monitoring device is not required on any EAF equipped with a DEC system if

**SECTION E. Source Group Restrictions.**

observations of shop opacity are performed by a certified visible emission observer as follows: Shop opacity observations shall be conducted at least once per day when the furnace is operating in the meltdown and refining period. Shop opacity shall be determined as the arithmetic average of 24 consecutive 15-second opacity observations of emissions from the shop taken in accordance with Method 9. Shop opacity shall be recorded for any point(s) where visible emissions are observed. Where it is possible to determine that a number of visible emission sites relate to only one incident of visible emissions, only one observation of shop opacity will be required. In this case, the shop opacity observations must be made for the site of highest opacity that directly relates to the cause (or location) of visible emissions observed during a single incident.

60.273a(e) A bag leak detection system must be installed and continuously operated on all single-stack fabric filters if the owner or operator elects not to install and operate a continuous opacity monitoring system as provided for under paragraph (c) of this section. In addition, the owner or operator shall meet the visible emissions observation requirements in paragraph (c) of this section. The bag leak detection system must meet the specifications and requirements of paragraphs (e)(1) through (8) of this section.

60.273a(e)(1) The bag leak detection system must be certified by the manufacturer to be capable of detecting particulate matter emissions at concentrations of 1 milligram per actual cubic meter (0.00044 grains per actual cubic foot) or less.

60.273a(e)(2) The bag leak detection system sensor must provide output of relative particulate matter loadings and the owner or operator shall continuously record the output from the bag leak detection system using electronic or other means (e.g., using a strip chart recorder or a data logger.)

60.273a(e)(3) The bag leak detection system must be equipped with an alarm system that will sound when an increase in relative particulate loading is detected over the alarm set point established according to paragraph (e)(4) of this section, and the alarm must be located such that it can be heard by the appropriate plant personnel.

60.273a(e)(4) For each bag leak detection system required by paragraph (e) of this section, the owner or operator shall develop and submit to the Administrator or delegated authority, for approval, a site-specific monitoring plan that addresses the items identified in paragraphs (i) through (v) of this paragraph (e)(4). For each bag leak detection system that operates based on the triboelectric effect, the monitoring plan shall be consistent with the recommendations contained in the U.S. Environmental Protection Agency guidance document "Fabric Filter Bag Leak Detection Guidance" (EPA-454/R-98-015). The owner or operator shall operate and maintain the bag leak detection system according to the site-specific monitoring plan at all times. The plan shall describe the following:

60.273a(e)(4)(i) Installation of the bag leak detection system;

60.273a(e)(4)(ii) Initial and periodic adjustment of the bag leak detection system including how the alarm set-point will be established;

60.273a(e)(4)(iii) Operation of the bag leak detection system including quality assurance procedures;

60.273a(e)(4)(iv) How the bag leak detection system will be maintained including a routine maintenance schedule and spare parts inventory list; and

60.273a(e)(4)(v) How the bag leak detection system output shall be recorded and stored.

60.273a(e)(5) The initial adjustment of the system shall, at a minimum, consist of establishing the baseline output by adjusting the sensitivity (range) and the averaging period of the device, and establishing the alarm set points and the alarm delay time (if applicable).

60.273a(e)(6) Following initial adjustment, the owner or operator shall not adjust the averaging period, alarm set point, or alarm delay time without approval from the Administrator or delegated authority except as provided for in paragraphs (e)(6)(i) and (ii) of this section.

60.273a(e)(6)(i) Once per quarter, the owner or operator may adjust the sensitivity of the bag leak detection system to account for seasonal effects including temperature and humidity according to the procedures identified in the site-specific monitoring plan required under paragraphs (e)(4) of this section.

**SECTION E. Source Group Restrictions.**

60.273a(e)(6)(ii) If opacities greater than zero percent are observed over four consecutive 15-second observations during the daily opacity observations required under paragraph (c) of this section and the alarm on the bag leak detection system does not sound, the owner or operator shall lower the alarm set point on the bag leak detection system to a point where the alarm would have sounded during the period when the opacity observations were made.

60.273a(e)(7) For negative pressure, induced air baghouses, and positive pressure baghouses that are discharged to the atmosphere through a stack, the bag leak detection sensor must be installed downstream of the baghouse and upstream of any wet scrubber.

60.273a(e)(8) Where multiple detectors are required, the system's instrumentation and alarm may be shared among detectors.

60.273a(f) For each bag leak detection system installed according to paragraph (e) of this section, the owner or operator shall initiate procedures to determine the cause of all alarms within 1 hour of an alarm. Except as provided for under paragraph (g) of this section, the cause of the alarm must be alleviated within 3 hours of the time the alarm occurred by taking whatever corrective action(s) are necessary. Corrective actions may include, but are not limited to, the following:

60.273a(f)(1) Inspecting the baghouse for air leaks, torn or broken bags or filter media, or any other condition that may cause an increase in particulate emissions;

60.273a(f)(2) Sealing off defective bags or filter media;

60.273a(f)(3) Replacing defective bags or filter media or otherwise repairing the control device;

60.273a(f)(4) Sealing off a defective baghouse compartment;

60.273a(f)(5) Cleaning the bag leak detection system probe or otherwise repairing the bag leak detection system; and

60.273a(f)(6) Shutting down the process producing the particulate emissions.

60.273a(g) In approving the site-specific monitoring plan required in paragraph (e)(4) of this section, the Administrator or delegated authority may allow owners or operators more than 3 hours to alleviate specific conditions that cause an alarm if the owner or operator identifies the condition that could lead to an alarm in the monitoring plan, adequately explains why it is not feasible to alleviate the condition within 3 hours of the time the alarm occurred, and demonstrates that the requested additional time will ensure alleviation of the condition as expeditiously as practicable.

[49 FR 43845, Oct. 31, 1984, as amended at 54 FR 6672, Feb. 14, 1989; 64 FR 10111, Mar. 2, 1999; 70 FR 8532, Feb. 22, 2005]

**# 005 [40 CFR Part 60 Standards of Performance for New Stationary Sources §40 CFR 60.274a]
Subpart AAa - Standards of Performance for Steel Plants: Electric Arc Furnaces and Argon-Oxygen Decarburization Vessels Constructed After August 7, 1983
Monitoring of operations.**

60.274a(a) The owner or operator subject to the provisions of this subpart shall maintain records of the following information:

60.274a(a)(1) All data obtained under paragraph (b) of this section; and

60.274a(a)(2) All monthly operational status inspections performed under paragraph (c) of this section.

60.274a(b) Except as provided under paragraph (e) of this section, the owner or operator subject to the provisions of this subpart shall check and record on a once-per-shift basis the furnace static pressure (if DEC system is in use, and a furnace static pressure gauge is installed according to paragraph (f) of this section) and either: check and record the control system fan motor amperes and damper position on a once-per-shift basis; install, calibrate, and maintain a monitoring device that continuously records the volumetric flow rate through each separately ducted hood; or install, calibrate, and maintain a monitoring device that continuously records the volumetric flow rate at the control device inlet and check and

**SECTION E. Source Group Restrictions.**

record damper positions on a once-per-shift basis. The monitoring device(s) may be installed in any appropriate location in the exhaust duct such that reproducible flow rate monitoring will result. The flow rate monitoring device(s) shall have an accuracy of ± 10 percent over its normal operating range and shall be calibrated according to the manufacturer's instructions. The Administrator may require the owner or operator to demonstrate the accuracy of the monitoring device(s) relative to Methods 1 and 2 of appendix A of this part.

60.274a(c) When the owner or operator of an affected facility is required to demonstrate compliance with the standards under § 60.272a(a)(3) and at any other time that the Administrator may require (under section 114 of the CAA, as amended) either: the control system fan motor amperes and all damper positions, the volumetric flow rate through each separately ducted hood, or the volumetric flow rate at the control device inlet and all damper positions shall be determined during all periods in which a hood is operated for the purpose of capturing emissions from the affected facility subject to paragraph (b) of this section. The owner or operator may petition the Administrator for reestablishment of these parameters whenever the owner or operator can demonstrate to the Administrator's satisfaction that the affected facility operating conditions upon which the parameters were previously established are no longer applicable. The values of these parameters as determined during the most recent demonstration of compliance shall be maintained at the appropriate level for each applicable period. Operation at other than baseline values may be subject to the requirements of § 60.276a(c). [DEP APPROVES ARCELOR'S 5/12/17 REQUEST TO OPERATE THE FAN'S MOTOR AT THE AVERAGE LEVEL DETERMINED DURING THE PERFORMANCE TESTING CONDUCTED ON 8/3-4/16. THIS PARAMETER LEVEL SHALL BE USED UNLESS AND UNTIL DEP WOULD APPROVE A DIFFERENT PARAMETER LEVEL IN WRITING]

60.274a(d) Except as provided under paragraph (e) of this section, the owner or operator shall perform monthly operational status inspections of the equipment that is important to the performance of the total capture system (i.e., pressure sensors, dampers, and damper switches). This inspection shall include observations of the physical appearance of the equipment (e.g., presence of holes in ductwork or hoods, flow constrictions caused by dents or accumulated dust in ductwork, and fan erosion). Any deficiencies shall be noted and proper maintenance performed.

60.274a(e) The owner or operator may petition the Administrator to approve any alternative to either the monitoring requirements specified in paragraph (b) of this section or the monthly operational status inspections specified in paragraph (d) of this section if the alternative will provide a continuous record of operation of each emission capture system.

60.274a(f) Except as provided for under § 60.273a(d), if emissions during any phase of the heat time are controlled by the use of a DEC system, the owner or operator shall install, calibrate, and maintain a monitoring device that allows the pressure in the free space inside the EAF to be monitored. The pressure shall be recorded as 15-minute integrated averages. The monitoring device may be installed in any appropriate location in the EAF or DEC duct prior to the introduction of ambient air such that reproducible results will be obtained. The pressure monitoring device shall have an accuracy of ± 5 mm of water gauge over its normal operating range and shall be calibrated according to the manufacturer's instructions.

60.274a(g) Except as provided for under § 60.273a(d), when the owner or operator of an EAF controlled by a DEC is required to demonstrate compliance with the standard under § 60.272a(a)(3), and at any other time the Administrator may require (under section 114 of the Clean Air Act, as amended), the pressure in the free space inside the furnace shall be determined during the meltdown and refining period(s) using the monitoring device required under paragraph (f) of this section. The owner or operator may petition the Administrator for reestablishment of the pressure whenever the owner or operator can demonstrate to the Administrator's satisfaction that the EAF operating conditions upon which the pressures were previously established are no longer applicable. The pressure determined during the most recent demonstration of compliance shall be maintained at all times when the EAF is operating in a meltdown and refining period. Operation at higher pressures may be considered by the Administrator to be unacceptable operation and maintenance of the affected facility.

60.274a(h) During any performance test required under § 60.8, and for any report thereof required by § 60.276a(f) of this subpart, or to determine compliance with § 60.272a(a)(3) of this subpart, the owner or operator shall monitor the following information for all heats covered by the test:

60.274a(h)(1) Charge weights and materials, and tap weights and materials;

60.274a(h)(2) Heat times, including start and stop times, and a log of process operation, including periods of no operation during testing and the pressure inside an EAF when direct-shell evacuation control systems are used;

**SECTION E. Source Group Restrictions.**

60.274a(h)(3) Control device operation log; and

60.274a(h)(4) Continuous opacity monitor or Method 9 data.

[49 FR 43845, Oct. 31, 1984, as amended at 64 FR 10111, Mar. 2, 1999; 65 FR 61758, Oct. 17, 2000; 70 FR 8533, Feb. 22, 2005]

006 [40 CFR Part 60 Standards of Performance for New Stationary Sources §40 CFR 60.275a]

Subpart Aa - Standards of Performance for Steel Plants: Electric Arc Furnaces and Argon-Oxygen Decarburization Vessels Constructed After August 7, 1983

Test methods and procedures.

60.275a(a) During performance tests required in § 60.8, the owner or operator shall not add gaseous diluents to the effluent gas stream after the fabric in any pressurized fabric filter collector, unless the amount of dilution is separately determined and considered in the determination of emissions.

60.275a(b) When emissions from any EAF(s) or AOD vessel(s) are combined with emissions from facilities not subject to the provisions of this subpart but controlled by a common capture system and control device, the owner or operator shall use either or both of the following procedures during a performance test (see also § 60.276a(e)):

60.275a(b)(1) Determine compliance using the combined emissions.

60.275a(b)(2) Use a method that is acceptable to the Administrator and that compensates for the emissions from the facilities not subject to the provisions of this subpart.

60.275a(c) When emission from any EAF(s) or AOD vessel(s) are combined with emissions from facilities not subject to the provisions of this subpart, the owner or operator shall demonstrate compliance with § 60.272(a)(3) based on emissions from only the affected facility(ies).

60.275a(d) In conducting the performance tests required in § 60.8, the owner or operator shall use as reference methods and procedures the test methods in appendix A of this part or other methods and procedures as specified in this section, except as provided in § 60.8(b).

60.275a(e) The owner or operator shall determine compliance with the particulate matter standards in § 60.272a as follows:

60.275a(e)(1) Method 5 shall be used for negative-pressure fabric filters and other types of control devices and Method 5D shall be used for positive-pressure fabric filters to determine the particulate matter concentration and volumetric flow rate of the effluent gas. The sampling time and sample volume for each run shall be at least 4 hours and 4.50 dscm (160 dscf) and, when a single EAF or AOD vessel is sampled, the sampling time shall include an integral number of heats.

60.275a(e)(2) When more than one control device serves the EAF(s) being tested, the concentration of particulate matter shall be determined using the following equation:

REFER TO REGULATION FOR EQUATION

where:

cst=average concentration of particulate matter, mg/dscm (gr/dscf).

csi=concentration of particulate matter from control device "i", mg/dscm (gr/dscf).

n=total number of control devices tested.

Qsdi=volumetric flow rate of stack gas from control device "i", dscm/hr (dscf/hr).

60.275a(e)(3) Method 9 and the procedures of § 60.11 shall be used to determine opacity.

60.275a(e)(4) To demonstrate compliance with § 60.272a(a) (1), (2), and (3), the Method 9 test runs shall be conducted concurrently with the particulate matter test runs, unless inclement weather interferes.

60.275a(f) To comply with § 60.274a (c), (f), (g), and (h), the owner or operator shall obtain the information required in

**SECTION E. Source Group Restrictions.**

these paragraphs during the particulate matter runs.

60.275a(g) Any control device subject to the provisions of the subpart shall be designed and constructed to allow measurement of emissions using applicable test methods and procedures.

60.275a(h) Where emissions from any EAF(s) or AOD vessel(s) are combined with emissions from facilities not subject to the provisions of this subpart but controlled by a common capture system and control device, the owner or operator may use any of the following procedures during a performance test:

60.275a(h)(1) Base compliance on control of the combined emissions;

60.275a(h)(2) Utilize a method acceptable to the Administrator that compensates for the emissions from the facilities not subject to the provisions of this subpart, or;

60.275a(h)(3) Any combination of the criteria of paragraphs (h)(1) and (h)(2) of this section.

60.275a(i) Where emissions from any EAF(s) or AOD vessel(s) are combined with emissions from facilities not subject to the provisions of this subpart, determinations of compliance with § 60.272a(a)(3) will only be based upon emissions originating from the affected facility(ies).

60.275a(j) Unless the presence of inclement weather makes concurrent testing infeasible, the owner or operator shall conduct concurrently the performance tests required under § 60.8 to demonstrate compliance with § 60.272a(a) (1), (2), and (3) of this subpart.

[49 FR 43845, Oct. 31, 1984, as amended at 54 FR 6673, Feb. 14, 1989; 54 FR 21344, May 17, 1989; 65 FR 61758, Oct. 17, 2000]

**# 007 [40 CFR Part 60 Standards of Performance for New Stationary Sources §40 CFR 60.276a]
Subpart AAa - Standards of Performance for Steel Plants: Electric Arc Furnaces and Argon-Oxygen Decarburization Vessels Constructed After August 7, 1983
Recordkeeping and reporting requirements.**

60.276a(a) Records of the measurements required in § 60.274a must be retained for at least 2 years following the date of the measurement.

60.276a(b) Each owner or operator shall submit a written report of exceedances of the control device opacity to the Administrator semi-annually. For the purposes of these reports, exceedances are defined as all 6-minute periods during which the average opacity is 3 percent or greater.

60.276a(c) Operation at a furnace static pressure that exceeds the value established under § 60.274a(g) and either operation of control system fan motor amperes at values exceeding ± 15 percent of the value established under § 60.274a(c) or operation at flow rates lower than those established under § 60.274a(c) may be considered by the Administrator to be unacceptable operation and maintenance of the affected facility. Operation at such values shall be reported to the Administrator semiannually.

60.276a(d) The requirements of this section remain in force until and unless EPA, in delegating enforcement authority to a State under section 111(c) of the Act, approves reporting requirements or an alternative means of compliance surveillance adopted by such State. In that event, affected sources within the State will be relieved of the obligation to comply with this section, provided that they comply with the requirements established by the State.

60.276a(e) When the owner or operator of an EAF or AOD is required to demonstrate compliance with the standard under § 60.275 (b)(2) or a combination of (b)(1) and (b)(2) the owner or operator shall obtain approval from the Administrator of the procedure(s) that will be used to determine compliance. Notification of the procedure(s) to be used must be postmarked at least 30 days prior to the performance test.

60.276a(f) For the purpose of this subpart, the owner or operator shall conduct the demonstration of compliance with § 60.272a(a) of this subpart and furnish the Administrator a written report of the results of the test. This report shall include the following information:

**SECTION E. Source Group Restrictions.**

60.276a(f)(1) Facility name and address;

60.276a(f)(2) Plant representative;

60.276a(f)(3) Make and model of process, control device, and continuous monitoring equipment;

60.276a(f)(4) Flow diagram of process and emission capture equipment including other equipment or process(es) ducted to the same control device;

60.276a(f)(5) Rated (design) capacity of process equipment;

60.276a(f)(6) Those data required under § 60.274a(h) of this subpart;

60.276a(f)(6)(i) List of charge and tap weights and materials;

60.276a(f)(6)(ii) Heat times and process log;

60.276a(f)(6)(iii) Control device operation log; and

60.276a(f)(6)(iv) Continuous opacity monitor or Method 9 data.

60.276a(f)(7) Test dates and test times;

60.276a(f)(8) Test company;

60.276a(f)(9) Test company representative;

60.276a(f)(10) Test observers from outside agency;

60.276a(f)(11) Description of test methodology used, including any deviation from standard reference methods;

60.276a(f)(12) Schematic of sampling location;

60.276a(f)(13) Number of sampling points;

60.276a(f)(14) Description of sampling equipment;

60.276a(f)(15) Listing of sampling equipment calibrations and procedures;

60.276a(f)(16) Field and laboratory data sheets;

60.276a(f)(17) Description of sample recovery procedures;

60.276a(f)(18) Sampling equipment leak check results;

60.276a(f)(19) Description of quality assurance procedures;

60.276a(f)(20) Description of analytical procedures;

60.276a(f)(21) Notation of sample blank corrections; and

60.276a(f)(22) Sample emission calculations.

60.276a(g) The owner or operator shall maintain records of all shop opacity observations made in accordance with § 60.273a(d). All shop opacity observations in excess of the emission limit specified in § 60.272a(a)(3) of this subpart shall indicate a period of excess emission, and shall be reported to the administrator semi-annually, according to § 60.7(c).

**SECTION E. Source Group Restrictions.**

60.276a(h) The owner or operator shall maintain the following records for each bag leak detection system required under § 60.273a(e):

60.276a(h)(1) Records of the bag leak detection system output;

60.276a(h)(2) Records of bag leak detection system adjustments, including the date and time of the adjustment, the initial bag leak detection system settings, and the final bag leak detection system settings; and

60.276a(h)(3) An identification of the date and time of all bag leak detection system alarms, the time that procedures to determine the cause of the alarm were initiated, if procedures were initiated within 1 hour of the alarm, the cause of the alarm, an explanation of the actions taken, the date and time the cause of the alarm was alleviated, and if the alarm was alleviated within 3 hours of the alarm.

[49 FR 43845, Oct. 31, 1984, as amended at 54 FR 6673, Feb. 14, 1989; 64 FR 10111, Mar. 2, 1999; 65 FR 61758, Oct. 17, 2000; 70 FR 8533, Feb. 22, 2005]

***** Permit Shield in Effect. *****

**SECTION E. Source Group Restrictions.**

Group Name: 12

Group Description: 40 CFR 60, Subpart Dc Boilers(s)

Sources included in this group

ID	Name
032A	BOILER (ZURN, 14M-350)
035A	BOILER (YORK-SHIPLEY, 582-SPH-650-XID)

I. RESTRICTIONS.

No additional requirements exist except as provided in other sections of this permit including Section B (Title V General Requirements).

II. TESTING REQUIREMENTS.

No additional testing requirements exist except as provided in other sections of this permit including Section B (Title V General Requirements).

III. MONITORING REQUIREMENTS.

No additional monitoring requirements exist except as provided in other sections of this permit including Section B (Title V General Requirements).

IV. RECORDKEEPING REQUIREMENTS.

No additional record keeping requirements exist except as provided in other sections of this permit including Section B (Title V General Requirements).

V. REPORTING REQUIREMENTS.

No additional reporting requirements exist except as provided in other sections of this permit including Section B (Title V General Requirements).

VI. WORK PRACTICE REQUIREMENTS.

No additional work practice requirements exist except as provided in other sections of this permit including Section B (Title V General Requirements).

VII. ADDITIONAL REQUIREMENTS.**# 001 [25 Pa. Code §127.441]****Operating permit terms and conditions.**

Regulatory Changes

Individual sources within this source group that are subject to 40 CFR Part 60, Subpart Dc—Standards of Performance for Small Industrial- Commercial-Institutional Steam Generating Units shall comply with all applicable requirements of the Subpart. 40 CFR 60.4(a) requires submission of copies of all requests, reports and other communications to both the Department and the EPA. The EPA copies shall be forwarded to:

Associate Director
 United States Environmental Protection Agency
 Region III, Enforcement & Compliance Assurance Division
 Air, RCRA and Toxics Branch (3ED21)
 Four Penn Center
 1600 John F. Kennedy Boulevard
 Philadelphia, Pennsylvania 19103-2852

The Department copies shall be forwarded to the DEP SCRO Air Quality Program Manager at wiveaver@pa.gov, unless otherwise directed in writing by DEP.

In the event that the Federal Subpart that is the subject of this Source Group is revised, the permittee shall comply with the

**SECTION E. Source Group Restrictions.**

revised version of the subpart, and shall not be required to comply with any provisions in this permit designated as having the subpart as their authority, to the extent that such permit provisions would be inconsistent with the applicable provisions of the revised subpart.

002 [40 CFR Part 60 Standards of Performance for New Stationary Sources §40 CFR 60.40c]**Subpart Dc - Standards of Performance for Small Industrial- Commercial-Institutional Steam Generating Units
Applicability and delegation of authority.**

60.40c(a) Except as provided in paragraphs (d), (e), (f), and (g) of this section, the affected facility to which this subpart applies is each steam generating unit for which construction, modification, or reconstruction is commenced after June 9, 1989 and that has a maximum design heat input capacity of 29 megawatts (MW) (100 million British thermal units per hour (MMBtu/h)) or less, but greater than or equal to 2.9 MW (10 MMBtu/h).

60.40c(b) In delegating implementation and enforcement authority to a State under section 111(c) of the Clean Air Act, § 60.48c(a)(4) shall be retained by the Administrator and not transferred to a State.

60.40c(c) [NA - UNITS NOT ASSOCIATED COMBUSTION RESEARCH]

60.40c(d) [NA - UNITS NOT ASSOCIATED COMBUSTION RESEARCH]

60.40c(e) [NA - UNITS NOT ASSOCIATED WITH STATIONARY COMBUSTION TURBINE]

60.40c(f) [NA - NOT SUBJECT TO NSPS AAAA OR CCCC]

60.40c(g) [NA - NOT SUBJECT TO NSPS BBBB]

60.40c(h) [NA - NOT SUBJECT TO NSPS J OR Ja]

60.40c(i) [NA - NOT TEMPORARY BOILERS]

[72 FR page 32759, June 13, 2007, as amended at 74 FR page 5090, Jan. 28, 2009; 77 FR page 9461, Feb. 16, 2012]

003 [40 CFR Part 60 Standards of Performance for New Stationary Sources §40 CFR 60.42c]**Subpart Dc - Standards of Performance for Small Industrial- Commercial-Institutional Steam Generating Units
Standard for sulfur dioxide.**

60.42c(a) [NA - UNITS NOT COAL FIRED]

60.42c(b) [NA - UNITS NOT COAL FIRED]

60.42c(c) [NA - UNITS NOT COAL FIRED]

60.42c(d) On and after the date on which the initial performance test is completed or required to be completed under § 60.8, whichever date comes first, no owner or operator of an affected facility that combusts oil shall cause to be discharged into the atmosphere from that affected facility any gases that contain SO₂ in excess of 215 ng/J (0.50 lb/MMBtu) heat input from oil; or, as an alternative, no owner or operator of an affected facility that combusts oil shall combust oil in the affected facility that contains greater than 0.5 weight percent sulfur. The percent reduction requirements are not applicable to affected facilities under this paragraph.

60.42c(e) [NA - MULTIPLE SIMULTANEOUS FUELS NOT USED]

60.42c(f) [NA - UNITS NOT COAL FIRED]

60.42c(g) [NA - PARAGRAPH (h) APPLIES]

60.42c(h) For affected facilities listed under paragraphs (h)(1), (2), (3), or (4) of this section, compliance with the emission limits or fuel oil sulfur limits under this section may be determined based on a certification from the fuel supplier, as described under § 60.48c(f), as applicable.

60.42c(h)(1) Distillate oil-fired affected facilities with heat input capacities between 2.9 and 29 MW (10 and 100 MMBtu/hr).

**SECTION E. Source Group Restrictions.**

60.42c(h)(2) [NA - UNITS NOT RESIDUAL OIL FIRED]

60.42c(h)(3) [NA - UNITS NOT COAL FIRED]

60.42c(h)(4) Other fuels-fired affected facilities with heat input capacities between 2.9 and 8.7 MW (10 and 30 MMBtu/h).

60.42c(i) The SO₂ emission limits, fuel oil sulfur limits, and percent reduction requirements under this section apply at all times, including periods of startup, shutdown, and malfunction.

60.42c(j) [NA - UNITS NOT IN NON-CONTINENTAL AREA]

[72 FR page 32759, June 13, 2007, as amended at 74 FR page 5090, Jan. 28, 2009; 77 FR page 9462, Feb. 16, 2012]

004 [40 CFR Part 60 Standards of Performance for New Stationary Sources §40 CFR 60.43c]

Subpart Dc - Standards of Performance for Small Industrial- Commercial-Institutional Steam Generating Units Standard for particulate matter.

60.43c(a) [NA - UNITS NOT COAL FIRED]

60.43c(b) [NA - UNITS NOT WOOD FIRED]

60.43c(c) On and after the date on which the initial performance test is completed or required to be completed under § 60.8, whichever date comes first, no owner or operator of an affected facility that combusts coal, wood, or oil and has a heat input capacity of 8.7 MW (30 MMBtu/h) or greater shall cause to be discharged into the atmosphere from that affected facility any gases that exhibit greater than 20 percent opacity (6-minute average), except for one 6-minute period per hour of not more than 27 percent opacity. Owners and operators of an affected facility that elect to install, calibrate, maintain, and operate a continuous emissions monitoring system (CEMS) for measuring PM emissions according to the requirements of this subpart and are subject to a federally enforceable PM limit of 0.030 lb/MMBtu or less are exempt from the opacity standard specified in this paragraph (c). [ONLY APPLIES TO SOURCE ID 032A]

60.43c(d) The PM and opacity standards under this section apply at all times, except during periods of startup, shutdown, or malfunction

60.43c(e)

60.43c(e)(1) - (3) [NA - COMPLIES WITH 60.43c(e)(4)]

60.43c(e)(4) An owner or operator of an affected facility that commences construction, reconstruction, or modification after February 28, 2005, and that combusts only oil that contains no more than 0.50 weight percent sulfur or a mixture of 0.50 weight percent sulfur oil with other fuels not subject to a PM standard under § 60.43c and not using a post-combustion technology (except a wet scrubber) to reduce PM or SO₂ emissions is not subject to the PM limit in this section.

[72 FR page 32759, June 13, 2007, as amended at 74 FR page 5091, Jan. 28, 2009; 77 FR page 9462, Feb. 16, 2012]

005 [40 CFR Part 60 Standards of Performance for New Stationary Sources §40 CFR 60.44c]

Subpart Dc - Standards of Performance for Small Industrial- Commercial-Institutional Steam Generating Units Compliance and performance test methods and procedures for sulfur dioxide.

60.44c(a) - (g) [NA - PARAGRAPH (h) APPLIES]

60.44c(h) For affected facilities subject to § 60.42c(h)(1), (2), or (3) where the owner or operator seeks to demonstrate compliance with the SO₂ standards based on fuel supplier certification, the performance test shall consist of the certification from the fuel supplier, as described in § 60.48c(f), as applicable.

60.44c(i) [NA - UNITS NOT COAL FIRED]

60.44c(j) [NA - PARAGRAPH (h) APPLIES]

[72 FR 32759, June 13, 2007, as amended at 74 FR 5091, Jan. 28, 2009]

**SECTION E. Source Group Restrictions.****# 006 [40 CFR Part 60 Standards of Performance for New Stationary Sources §40 CFR 60.45c]****Subpart Dc - Standards of Performance for Small Industrial- Commercial-Institutional Steam Generating Units Compliance and performance test methods and procedures for particulate matter.**

60.45c(a) [NA - NOT SUBJECT TO PM OR OPACITY STANDARD]

60.45c(b) [NA - NOT SUBJECT PM STANDARD UNDER 60.43c(b)(2)]

60.45c(c) [NA - NOT SUBJECT TO PM STANDARD]

60.45c(d) The owner or operator of an affected facility seeking to demonstrate compliance under § 60.43c(e)(4) shall follow the applicable procedures under § 60.48c(f). For residual oil-fired affected facilities, fuel supplier certifications are only allowed for facilities with heat input capacities between 2.9 and 8.7 MW (10 to 30 MMBtu/h).

[72 FR page 32759, June 13, 2007, as amended at 74 FR page 5091, Jan. 28, 2009; 76 FR page 3523, Jan. 20, 2011; 77 FR page 9463, Feb. 16, 2012]

007 [40 CFR Part 60 Standards of Performance for New Stationary Sources §40 CFR 60.46c]**Subpart Dc - Standards of Performance for Small Industrial- Commercial-Institutional Steam Generating Units Emission monitoring for sulfur dioxide**

60.46c(a) - (d) [NA - PARAGRAPH (e) APPLIES]

60.46c(e) The monitoring requirements of paragraphs (a) and (d) of this section shall not apply to affected facilities subject to § 60.42c(h) (1), (2), or (3) where the owner or operator of the affected facility seeks to demonstrate compliance with the SO₂ standards based on fuel supplier certification, as described under § 60.48c(f), as applicable.

60.46c(f) [NA - PARAGRAPH (e) APPLIES]

008 [40 CFR Part 60 Standards of Performance for New Stationary Sources §40 CFR 60.47c]**Subpart Dc - Standards of Performance for Small Industrial- Commercial-Institutional Steam Generating Units Emission monitoring for particulate matter.**

60.47c(a) - (f) [NA - NOT SUBJECT TO PM LIMIT OR OPACITY STANDARD]

[72 FR page 32759, June 13, 2007, as amended at 74 FR page 5091, Jan. 28, 2009; 76 FR page 3523, Jan. 20, 2011; 77 FR page 9463, Feb. 16, 2012]

009 [40 CFR Part 60 Standards of Performance for New Stationary Sources §40 CFR 60.48c]**Subpart Dc - Standards of Performance for Small Industrial- Commercial-Institutional Steam Generating Units Reporting and recordkeeping requirements.**

60.48c(a) [NA - STARTUP IS IN THE PAST]

60.48c(b) The owner or operator of each affected facility subject to the SO₂ emission limits of § 60.42c, or the PM or opacity limits of § 60.43c, shall submit to the Administrator the performance test data from the initial and any subsequent performance tests and, if applicable, the performance evaluation of the CEMS and/or COMS using the applicable performance specifications in appendix B of this part.

60.48c(c) [NA - NOT SUBJECT TO OPACITY STANDARD]

60.48c(d) The owner or operator of each affected facility subject to the SO₂ emission limits, fuel oil sulfur limits, or percent reduction requirements under § 60.42c shall submit reports to the Administrator.

60.48c(e) The owner or operator of each affected facility subject to the SO₂ emission limits, fuel oil sulfur limits, or percent reduction requirements under § 60.42c shall keep records and submit reports as required under paragraph (d) of this section, including the following information, as applicable.

60.48c(e)(1) Calendar dates covered in the reporting period.

60.48c(e)(2) - (10) [NA - FUEL SUPPLIER CERTIFICATION USED]

**SECTION E. Source Group Restrictions.**

60.48c(e)(11) If fuel supplier certification is used to demonstrate compliance, records of fuel supplier certification as described under paragraph (f)(1), (2), (3), or (4) of this section, as applicable. In addition to records of fuel supplier certifications, the report shall include a certified statement signed by the owner or operator of the affected facility that the records of fuel supplier certifications submitted represent all of the fuel combusted during the reporting period.

60.48c(f) Fuel supplier certification shall include the following information:

60.48c(f)(1) For distillate oil:

60.48c(f)(1)(i) The name of the oil supplier;

60.48c(f)(1)(ii) A statement from the oil supplier that the oil complies with the specifications under the definition of distillate oil in § 60.41c; and

60.48c(f)(1)(iii) The sulfur content or maximum sulfur content of the oil.

60.48c(f)(2) [NA - RESIDUAL OIL NOT COMBUSTED]

60.48c(f)(3) [NA - UNITS NOT COAL FIRED]

60.48c(f)(4) For other fuels:

60.48c(f)(4)(i) The name of the supplier of the fuel;

60.48c(f)(4)(ii) The potential sulfur emissions rate or maximum potential sulfur emissions rate of the fuel in ng/J heat input; and

60.48c(f)(4)(iii) The method used to determine the potential sulfur emissions rate of the fuel.

60.48c(g)

60.48c(g)(1) Except as provided under paragraphs (g)(2) and (g)(3) of this section, the owner or operator of each affected facility shall record and maintain records of the amount of each fuel combusted during each operating day.

60.48c(g)(2) As an alternative to meeting the requirements of paragraph (g)(1) of this section, the owner or operator of an affected facility that combusts only natural gas, wood, fuels using fuel certification in § 60.48c(f) to demonstrate compliance with the SO₂ standard, fuels not subject to an emissions standard (excluding opacity), or a mixture of these fuels may elect to record and maintain records of the amount of each fuel combusted during each calendar month.

60.48c(g)(3) As an alternative to meeting the requirements of paragraph (g)(1) of this section, the owner or operator of an affected facility or multiple affected facilities located on a contiguous property unit where the only fuels combusted in any steam generating unit (including steam generating units not subject to this subpart) at that property are natural gas, wood, distillate oil meeting the most current requirements in § 60.42C to use fuel certification to demonstrate compliance with the SO₂ standard, and/or fuels, excluding coal and residual oil, not subject to an emissions standard (excluding opacity) may elect to record and maintain records of the total amount of each steam generating unit fuel delivered to that property during each calendar month.

60.48c(h) [NA - UNITS NOT SUBJECT TO REQUIREMENT LIMITING THE ANNUAL CAPACITY FACTOR]

60.48c(i) All records required under this section shall be maintained by the owner or operator of the affected facility for a period of two years following the date of such record.

60.48c(j) The reporting period for the reports required under this subpart is each six-month period. All reports shall be submitted to the Administrator and shall be postmarked by the 30th day following the end of the reporting period. [SIX MONTH PERIODS SHALL BE DEFINED AS CALENDAR HALVES]

[72 FR 32759, June 13, 2007, as amended at 74 FR 5091, Jan. 28, 2009]



SECTION E. Source Group Restrictions.

***** Permit Shield in Effect. *****

**SECTION E. Source Group Restrictions.**

Group Name: 13

Group Description: §§129.91 - 129.95 - RACT I Requirements

Sources included in this group

ID	Name
033	PLANT HOT WATER HEATERS
034	SHOP SPACE HEATERS
102	CONTROLLED COOLING BOXES 1 - 8
109	EAF LADLE PREHEATERS 1-4
113	BURN OFF OVEN
114	CONTIN. CASTER TUNDISH PREHTR. 1 & 2
116	CONTINUOUS CASTER TUNDISH DRYER 1
118	CASTER CUTTING TORCHES 1-6
124	CASTER VENTS
232C	20" MILL REHEAT FURNACE
301	35" MILL REHEAT FURNACES 3 & 4
401	SOAKING PIT BATTERIES 4-6
500	VACUUM DEGASSER @ STEELMAKING
501A	#207 DCEAF
501B	LADLE REFINING FURNACE
921	PARTS WASHERS
922	COMPRESSED AIR SYSTEM FREEZE PROTECTION

I. RESTRICTIONS.**Emission Restriction(s).****# 001 [25 Pa. Code §127.441]****Operating permit terms and conditions.**

ArcelorMittal Steelton, LLC (formerly Bethlehem Steel Corp.)
 Steelton Borough, Dauphin County
 RACT Operating Permit No. 22-02012 SIP requirements

I. List of Steel Production Sources and NOx Emissions

Source: Manufacturer: Rated Heat Input: Annual Emission Limit:
 #207 DC Electric Arc Furnace (DCEAF): NKK United: --: 99 tpy [SOURCE 501A]
 Ladle Refining Furnace: EMC1: --: -- [SOURCE 501B]
 Vacuum Degasser: EMC1: --: -- [SOURCE 500]
 #209 Electric Arc Furnace: Lectromelt: --: 72 tpy [SOURCE HAS BEEN REMOVED]

II. List of Combustion Units/Sources > 50 mmBtu.hr and NOx Emissions

Source: Manufacturer: Rated Heat Input: Annual Emission Limit:
 Central Boiler #2 (NG or #6 Oil Fired): Erie City: 200 MMBtu/hr: 253 tpy [SOURCE HAS BEEN REMOVED]
 Central Boiler #5 (NG or #6 Oil Fired): Erie City: 200 MMBtu/hr: 253 tpy [SOURCE HAS BEEN REMOVED]
 20" Mill Reheat Furnace (NG or #6 Oil Fired): Rust Engineering: 180 MMBtu/hr: 189.0 tpy [SOURCE 232C]

III. List of Combustion Sources of Rated Capacity between 20 - 50 mmBtu/hr and NOx Emissions, Natural Gas Fired (Soaking Pits also #6 Oil Fired)

Source: Manufacturer: Rated Heat Input: Annual Emission Limit:
 Soaking Pit Battery #5: Burners NG Fired - Combustion Eng (CE); Oil- Bloom Eng (BE): 48 MMBtu/hr: 37.8 tpy [SOURCE 401]
 Soaking Pit Battery #6: BE/CE: 48 MMBtu/hr: 37.8 tpy [SOURCE 401]

**SECTION E. Source Group Restrictions.**

Soaking Pit Battery #1:BE/CE: 48 MMBtu/hr: 37.8 tpy [SOURCE HAS BEEN REMOVED]
 Soaking Pit Battery #2:BE/CE: 48 MMBtu/hr: 37.8 tpy [SOURCE HAS BEEN REMOVED]
 Soaking Pit Battery #3:BE/CE: 48 MMBtu/hr: 37.8 tpy [SOURCE HAS BEEN REMOVED]
 Soaking Pit Battery #4:BE/CE: 48 MMBtu/hr: 37.8 tpy[SOURCE 401]
 35" Mill Reheat Furnace #3: Bethlehem Steel Corp. (BSC): 40 MMBtu/hr: 152.8 tpy [SOURCE 301]
 35" Mill Reheat Furnace #4: BSC: 40 MMBtu/hr: 152.8 tpy [SOURCE 301]
 Pipe Mill Dravo Heater: Dravo: 37.5 MMBtu/hr: 22.2 tpy [SOURCE HAS BEEN REMOVED]
 Rail Mill #1 Heat Furnace: BE: 37.8 MMBtu/hr: 13.8 tpy [SOURCE HAS BEEN REMOVED]
 Rail Mill #1 Draw Furnace: BE: 26.8 MMBtu/hr: 6.2 tpy [SOURCE HAS BEEN REMOVED]

IV. List of Combustion Sources of Rated Capacity 2.5 mmBtu/hr and < 20 mmBtu/hr, Natural Gas Fired, Subject to Presumptive RACT as per Condition 19:

Source: Manufacturer: Rated Heat Input

Ladle Preheater #1: BE: 9.9 MMBtu/hr [SOURCE 109]
 Ladle Preheater #2: BE: 9.9 MMBtu/hr [SOURCE 109]
 Ladle Preheater #3: BE: 9.9 MMBtu/hr [SOURCE 109]
 Ladle Preheater #4: North American (NA): 9.9 MMBtu/hr [SOURCE 109]
 Continuous Caster Tundish Preheater #1: Friedrich Ley (FL): 9.9 MMBtu/hr [SOURCE 114]
 Continuous Caster Tundish Preheater #2: FL: 9.9 MMBtu/hr [SOURCE 114]
 Continuous Caster Tundish Dryer #1: not known: 4.6 MMBtu/hr [SOURCE 116]
 Pipe Mill Cooling IR Heater: NA: 3.8 MMBtu/hr [SOURCE HAS BEEN REMOVED]

V. List of Combustion Sources Rated Capacity < 2.5 mmBtu/hr and listed for RACT Review, Natural Gas Fired

Controlled Cooling Box #1: Kirk Blum (KB): 0.6 MMBtu/hr
 Controlled Cooling Box #2: KB: 0.6 MMBtu/hr [SOURCE 102]
 Controlled Cooling Box #3: KB: 0.6 MMBtu/hr [SOURCE 102]
 Controlled Cooling Box #4: KB: 0.6 MMBtu/hr [SOURCE 102]
 Controlled Cooling Box #5: KB: 0.6 MMBtu/hr [SOURCE 102]
 Controlled Cooling Box #6: KB: 0.6 MMBtu/hr [SOURCE 102]
 Controlled Cooling Box #7: KB: 0.6 MMBtu/hr [SOURCE 102]
 Controlled Cooling Box #8: KB: 0.6 MMBtu/hr [SOURCE 102]
 Burn Off Oven: ACE: 0.5 MMBtu/hr [SOURCE 113]
 Caster Cutting Torch #1 thru #6: --: 0.123 MMBtu/hr [SOURCE 118]
 Six Hot Water Heaters and Space Heaters: --: < 0.5 MMBtu/hr each (Combined Emissions Potential < 13 tpy NOx) [SOURCES 033 AND 034]

(4)(a) NOx emissions from the facility shall not exceed 1,206 tpy based on a 12-month rolling total.

(b) NOx emissions from each of the sources listed in source items I through III shall be equal to or below the quantity as stated therein, and the emissions shall be based on a 12-month rolling total.

(5) VOC emissions from the facility shall not exceed 210 tpy based on a 12-month rolling total.

(6) VOC emissions shall not exceed the following limits, based on a 12-month rolling total:

- (a) DC EAF/LRF - 81 tpy [SOURCES 501A AND 501B]
- (b) EAF 209/LRF - combined steel production, included in (a) above. [SOURCE HAS BEEN REMOVED]
- (c) Central Boilers #2 and #5 - 9 tpy [SOURCES HAVE BEEN REMOVED]
- (d) 20" Mill Reheat Furnace - Natural Gas - 5 tpy; #6 Oil - 5 tpy. [SOURCE 232C]
- (e) Soaking Pit Batteries #1 through #6 - Natural Gas - 8 tpy; #6 Oil - 8 tpy. [SOURCE 401]
- (f) 35" Mill Reheat Furnace - 0.6 tpy [SOURCE 301]
- (g) Pipe Mill Dravo Heater - 0.2 tpy [SOURCE HAS BEEN REMOVED]
- (h) Rail Mill #1 Heat Furnace - 2.2 tpy [SOURCE HAS BEEN REMOVED]
- (i) Rail Mill #1 Draw Furnace - 16 tpy [SOURCE HAS BEEN REMOVED]
- (j) Two Caster Steam Vents - 17.8 tpy [SOURCE 124]
- (k) Oil Quench Tank for Rails Heat Treatment - 31.5 tpy [SOURCE HAS BEEN REMOVED]

**SECTION E. Source Group Restrictions.**

- (l) Compressed Air System Freeze Protection - 13.4 tpy [SOURCE 922]
- (m) Inking of Rails Operation - 5 tpy [SOURCE HAS BEEN REMOVED]
- (n) Parts Washer Cleaning Solvent for Maintenance - 24.7 tpy [SOURCE 921]

(7) The following sources shall not exceed the annual capacity as noted:

- (a) Boilers #2 and #5 – combined heat input of 250 MMBtu/hr [SOURCES HAVE BEEN REMOVED]
- (b) 20" Mill Reheat Furnace - 100,000 tons steel, based on a 12-month rolling total [SOURCE 232C]
- (c) 35" Mill Reheat Furnaces #3 and #4 - Combined 600,000 tons steel, based on a 12-month rolling total [SOURCE 301]
- (d) Soaking Pit Batteries #1 through #6 - Combined 1,000,000 tons steel, based on a 12-month rolling total [SOURCE 401]

(8) Stack testing to determine the emissions rate of VOC and NO_x as NO₂ shall be performed in Central Boilers #2 and #5 at normal winter load annually. First stack test shall be performed within 365 days of issue of this operating permit. Subsequent stack test may be performed on one representative of the boilers. [SOURCES HAVE BEEN REMOVED]

(9) Stack testing to determine the emissions rate of NO_x as NO₂ shall be performed on Sources in Item III (except for the Pipe Mill Dravo Heater). One representative of the stacks in each of the following groups of heating furnaces shall be stack tested:

- (a) Soaking Pit Batteries #1 through #4 [SOURCE 401, BUT #1, #2 AND #3 HAVE BEEN REMOVED]
- (b) Soaking Pit Batteries #5 and #6 [SOURCE 401]
- (c) 35" Reheat Furnaces #3 and #4 [SOURCE 301]
- (d) Rail Mill #1 Heat Furnace and Draw Furnace [SOURCES HAVE BEEN REMOVED]

(10) Stack testing to determine the emissions rate of VOC shall be performed on one representative of the stack on Soaking Pit Batteries #1 through #6 on #6 oil. [SOURCE 401, BUT #1, #2 AND #3 HAVE BEEN REMOVED]

(11) Stack test for the heating furnaces listed in Conditions 9 and 10 shall be performed within 365 days of issue of this operating permit. The Department reserves the right to order further stack tests. [REQUIREMENT IS IN THE PAST]

(12) Stack testing shall be performed in accordance with 25 Pa. Code Chapter 139 and the current version of the Department's Source Testing Manual, or by other means, proposed by Bethlehem Steel and approved by the Department.

(13) A Stack Test Protocol is to be submitted to the Air Quality Program Manager for approval at least 60 days prior to stack test.

(14) The Department shall be notified at least two weeks in advance of the date and time of the stack test.

(15) Two copies of the stack test results shall be submitted to the Air Quality Program Manager for review within 60 days of completion of testing. Results shall be reported as follows:

- (a) Concentration in ppm as measured
- (b) Mass and heat rates in lb/hr and lb/MMBtu

[COMPLIANCE WITH SECTION C, #009 ENSURES COMPLIANCE WITH THIS CONDITION]

(16) Facility shall demonstrate compliance of NO_x emission from DC Electric Arc Furnace, Ladle Refining Furnace and Vacuum Degasser through continuous emission monitoring system installed for the melt shop. [THIS APPLIES TO THE 99 TPY NO_x LIMIT NOTED ABOVE]

(17) This operating permit is for the incorporation of the Department's NO_x and VOC Reasonably Available Control Technology (RACT) requirements (25 Pa. Code Sections 129.91 through 129.95).

[Note: the SIP-ed RACT 1 permit had no Condition 18]

(19) The company shall maintain and operate the combustion sources of heat input capacities each rated at or over 2.5

**SECTION E. Source Group Restrictions.**

mmbtu/hr but less than 20 mmbtu/hr as per 25 Pa. Code Section 129.93(c), condition for presumptive RACT. The presumptive RACT limitations are installation, maintenance and operation of the sources listed in Source Item IV, in accordance with manufacturers' specifications. [THIS APPLIES TO SOURCES 109, 114 AND 116]

(20) Boilers #2 and #5, Soaking Pit Batteries #1 through #6, and 20" Mill Reheat Furnaces are subject to the following: [OF THESE UNITS, ONLY SOAKING PIT BATTERIES #4, #5 AND #6, AND THE 20" MILL REHEAT FURNACES REMAIN AT THE FACILITY]

(a) The company shall perform an annual adjustment and/or tune-up which shall include the following:

(1) Inspection, adjustment, cleaning or replacement of fuel-burning equipment, including the burners and moving parts necessary for proper operation as specified by the manufacturer.

(2) Inspection of the flame pattern or characteristics and adjustments necessary to minimize emissions of NO_x and VOC.

(3) Inspection of the air-to-fuel ratio control system and adjustments necessary to ensure proper calibration and operation as specified by the manufacturer.

(b) The company shall maintain a permanently bound log book or other method approved by the Department. This log shall contain at a minimum, the following information.

(1) The date of the tuning procedure

(2) The name of the service company and technicians

(3) The final operating rate or load

(4) The final NO_x and VOC emission rates

(5) The final excess oxygen rate

(6) Any other information required by this approval

(c) The annual adjustment for the boilers shall be in accordance with the EPA document "Combustion Efficiency Optimization Manual for Operations of Oil and Gas-Fired Boilers", September 1983 (EPA-340/1-83-023) or equivalent procedures approved in writing by the Department.

(d) All adjustments and optimization of the units must minimize pollution and be in accordance with good air pollution control practices.

(21) The company shall comply with the following "housekeeping" procedures with the intent to regulate Parts Washer Cleaning Solvent and maintenance: [THIS APPLIES TO SOURCE 921]

(a) Cleanup solvents and used rags will be contained in a closed container with a lid at all times.

(b) Routine inspections of the containers will be made by the company to assure no leakage in the containers.

(c) Precautionary steps will be taken to prevent spillage of clean-up solvent while transferring from point-to-point.

(d) Rags will be sent to reclamation as early as possible or disposed off-site by a permitted company.

(22) Records shall be maintained in accordance with 25 Pa. Code, § 129.95 requirements.

(23) For the sources listed above Condition 6, the company shall keep separate records of monthly usage and VOC contents of each source specific VOC containing fluids

(24)(a) For the sources listed in source items I through IV, the company shall keep separate records of monthly fuel usage and emissions

(b) Gas consumption for Tundishes [SOURCES 114 AND 116] and Pipe Mill Dravo Heater [SOURCE HAS BEEN REMOVED] may be measured in groups. Gas and oil usage for six Soaking Pit Batteries [ONLY THREE REMAIN] may be recorded and reported as a group for all batteries combined.

(c) The annual facility emissions shall be calculated and recorded based on a 12-month rolling total.

(d) The annual emission limits for the sources listed in Condition 6 and fire source items I through III shall be calculated

**SECTION E. Source Group Restrictions.**

and recorded based on a 12-month rolling total.

(25) Records listed above shall be retained for two years, and made available to the Department upon request.

(26) An annual emissions report including the monthly records of fuel usage, operating hours, inventory of solvents, clean-up solvents usage, and its return for recycling for the sources listed in this operating permit shall be submitted [to] the Harrisburg District Supervisor as per 25 Pa. Code § 135.3. The report for January 1 through December 31 is due no later than March 1 of the following year for each operating year authorized by the operating Permit or its renewal.

[Note: the SIP-ed RACT 1 permit had no Condition 27]

(28) The Controlled Cooling Box #1 through #8, Burn Off Oven and six hot water heaters and space heaters listed in the Source Item V shall be operated and maintained in accordance with the respective manufacturer's specifications.

Note: The case-by-case RACT 2 requirements in Group 15 were SIP'd by EPA on 1/26/22. The following conditions above were superseded by the case-by-case RACT 2 requirements in Group 15: Group 13, Conditions 9-15, and 20.

II. TESTING REQUIREMENTS.

No additional testing requirements exist except as provided in other sections of this permit including Section B (Title V General Requirements).

III. MONITORING REQUIREMENTS.

No additional monitoring requirements exist except as provided in other sections of this permit including Section B (Title V General Requirements).

IV. RECORDKEEPING REQUIREMENTS.

No additional record keeping requirements exist except as provided in other sections of this permit including Section B (Title V General Requirements).

V. REPORTING REQUIREMENTS.

No additional reporting requirements exist except as provided in other sections of this permit including Section B (Title V General Requirements).

VI. WORK PRACTICE REQUIREMENTS.

No additional work practice requirements exist except as provided in other sections of this permit including Section B (Title V General Requirements).

VII. ADDITIONAL REQUIREMENTS.

No additional requirements exist except as provided in other sections of this permit including Section B (Title V General Requirements).

***** Permit Shield in Effect. *****

**SECTION E. Source Group Restrictions.**

Group Name: 14

Group Description: §§129.96 - 129.100 - RACT II Presumptive Requirements

Sources included in this group

ID	Name
032A	BOILER (ZURN, 14M-350)
035A	BOILER (YORK-SHIPLEY, 582-SPH-650-XID)
109	EAF LADLE PREHEATERS 1-4
114	CONTIN. CASTER TUNDISH PREHTR. 1 & 2
116	CONTINUOUS CASTER TUNDISH DRYER 1
129	RAILROAD CAR INGOT HEATERS
137	RAIL STENCILING
138	SCRAP PREPARATION

I. RESTRICTIONS.

No additional requirements exist except as provided in other sections of this permit including Section B (Title V General Requirements).

II. TESTING REQUIREMENTS.

No additional testing requirements exist except as provided in other sections of this permit including Section B (Title V General Requirements).

III. MONITORING REQUIREMENTS.

No additional monitoring requirements exist except as provided in other sections of this permit including Section B (Title V General Requirements).

IV. RECORDKEEPING REQUIREMENTS.

No additional record keeping requirements exist except as provided in other sections of this permit including Section B (Title V General Requirements).

V. REPORTING REQUIREMENTS.

No additional reporting requirements exist except as provided in other sections of this permit including Section B (Title V General Requirements).

VI. WORK PRACTICE REQUIREMENTS.

No additional work practice requirements exist except as provided in other sections of this permit including Section B (Title V General Requirements).

VII. ADDITIONAL REQUIREMENTS.**# 001 [25 Pa. Code §127.441]****Operating permit terms and conditions.**

(a) Source ID 035A. In accordance with 25 Pa. Code §129.97(b), the owner and operator of a source specified in this subsection, which is located at a major NOx emitting facility or major VOC emitting facility subject to § 129.96 shall comply with the following:

(1) The presumptive RACT requirement for a combustion unit with a rated heat input equal to or greater than 20 million Btu/hour and less than 50 million Btu/hour, which is the performance of a biennial tune-up conducted in accordance with the procedures in 40 CFR 63.11223 (relating to how do I demonstrate continuous compliance with the work practice and management practice standards). The biennial tune-up must include, at a minimum, the following:

(i) Inspection and cleaning or replacement of fuel-burning equipment, including the burners and components, as necessary, for proper operation as specified by the manufacturer.

(ii) Inspection of the flame pattern and adjustment of the burner, as necessary, to optimize the flame pattern to minimize

**SECTION E. Source Group Restrictions.**

total emissions of NO_x and, to the extent possible, emissions of CO.

(iii) Inspection and adjustment, as necessary, of the air-to-fuel ratio control system to ensure proper calibration and operation as specified by the manufacturer.

(b) Source ID 032A. In accordance with 25 Pa. Code §129.97(g)(1)(i) & (ii), except as specified under subsection (c), the owner and operator of a NO_x air contamination source specified in this subsection, which is located at a major NO_x emitting facility or a VOC air contamination source specified in this subsection, which is located at a major VOC emitting facility subject to § 129.96 may not cause, allow or permit NO_x or VOCs to be emitted from the air contamination source in excess of the applicable presumptive RACT emission limitation:

(1) A combustion unit or process heater:

(i) For a natural gas-fired combustion unit or process heater with a rated heat input equal to or greater than 50 million Btu/hour, 0.10 lb NO_x/million Btu heat input.

(ii) For a distillate oil-fired combustion unit or process heater with a rated heat input equal to or greater than 50 million Btu/hour, 0.12 lb NO_x/million Btu heat input.

(c) The permittee shall install, maintain and operate the sources in accordance with the manufacturer's specifications and with good operating practices pursuant to 25 Pa Code § 129.97(c)(1) and (c)(2). Specifically:

(1) 25 Pa Code §129.97(c)(1): Source IDs 109, 114, 116, 129, 138

(2) 25 Pa Code §129.97(c)(2): Source IDs 032A, 137

(d) In accordance with 25 Pa. Code §129.100(a), except as provided in §129.100(c), the owner and operator of an air contamination source subject to a NO_x RACT requirement or RACT emission limitation or VOC RACT requirement or RACT emission limitation, or both, listed in §129.97 (relating to presumptive RACT requirements, RACT emission limitations and petition for alternative compliance schedule) shall demonstrate compliance with the applicable RACT requirement or RACT emission limitation by performing the following monitoring or testing procedures:

(1) For an air contamination source without a CEMS, monitoring and testing in accordance with a Department-approved emissions source test that meets the requirements of Chapter 139, Subchapter A (relating to sampling and testing methods and procedures). The source test shall be conducted one time in each 5-year calendar period. [PER DEP'S "RESPONSES TO FREQUENTLY ASKED QUESTIONS" TO THE FINAL RULEMAKING, ADDITIONAL RACT REQUIREMENTS FOR MAJOR SOURCES OF NO_x AND VOCs, 25 PA. CODE CHAPTERS 121 AND 129, 46 PA. B. 2036 (APRIL 23, 2016) UPDATED 10/20/16, DEP DEFINES THE TERM "5-YEAR CALENDAR PERIOD" AS: "... A FIVE CALENDAR YEAR PERIOD BEGINNING WITH THE CALENDAR YEAR THAT THE LATEST STACK TEST IS PERFORMED. FOR EXAMPLE, IF THE OWNER OR OPERATOR PERFORMS A STACK TEST FOR NO_x RACT COMPLIANCE IN 2016, THEN A SUBSEQUENT STACK TEST SHALL BE CONDUCTED BY THE END OF 2021... "]

(e) In accordance with 25 Pa. Code §129.100(d), the owner and operator of an air contamination source subject to §129.100 and §§129.96—129.99 shall keep records to demonstrate compliance with §§129.96—129.99 in the following manner:

(1) The records must include sufficient data and calculations to demonstrate that the requirements of §§129.96—129.99 are met.

(2) Data or information required to determine compliance shall be recorded and maintained in a time frame consistent with the averaging period of the requirement.

(f) In accordance with 25 Pa. Code §129.100(g), The owner or operator of a combustion unit subject to §129.97(b) shall record each adjustment conducted under the procedures in §129.97(b). This record must contain, at a minimum:

(1) The date of the tuning procedure.

(2) The name of the service company and the technician performing the procedure.

**SECTION E. Source Group Restrictions.**

(3) The final operating rate or load.

(4) The final NOx and CO emission rates.

(5) The final excess oxygen rate.

(6) Other information required by the applicable operating permit.

(g) In accordance with 25 Pa. Code §129.100(i), all records shall be retained by the owner or operator for 5 years and made available to the Department or appropriate approved local air pollution control agency upon receipt of a written request from the Department or appropriate approved local air pollution control agency.

***** Permit Shield in Effect. *****

**SECTION E. Source Group Restrictions.**

Group Name: 15

Group Description: §§129.96 - 129.100 - RACT II Case-by-Case Requirements

Sources included in this group

ID	Name
124	CASTER VENTS
132A	44" MILL HOT ROLLING OPERATIONS
132B	28"/35" MILL HOT ROLLING OPERATIONS
132C	20" MILL HOT ROLLING OPERATIONS
232C	20" MILL REHEAT FURNACE
301	35" MILL REHEAT FURNACES 3 & 4
401	SOAKING PIT BATTERIES 4-6
501A	#207 DCEAF
501B	LADLE REFINING FURNACE
922	COMPRESSED AIR SYSTEM FREEZE PROTECTION

I. RESTRICTIONS.

No additional requirements exist except as provided in other sections of this permit including Section B (Title V General Requirements).

II. TESTING REQUIREMENTS.

No additional testing requirements exist except as provided in other sections of this permit including Section B (Title V General Requirements).

III. MONITORING REQUIREMENTS.

No additional monitoring requirements exist except as provided in other sections of this permit including Section B (Title V General Requirements).

IV. RECORDKEEPING REQUIREMENTS.

No additional record keeping requirements exist except as provided in other sections of this permit including Section B (Title V General Requirements).

V. REPORTING REQUIREMENTS.

No additional reporting requirements exist except as provided in other sections of this permit including Section B (Title V General Requirements).

VI. WORK PRACTICE REQUIREMENTS.

No additional work practice requirements exist except as provided in other sections of this permit including Section B (Title V General Requirements).

VII. ADDITIONAL REQUIREMENTS.**# 001 [25 Pa. Code §127.441]****Operating permit terms and conditions.**

I. Sources 232C (20" Mill Reheat Furnace) and 301 (35" Mill Reheat Furnaces 3 & 4)

(a) The permittee shall perform an annual adjustment and/or tune-up on each unit which shall include the following:

- (1) Inspection, adjustment, cleaning or replacement of fuel-burning equipment, including the burners and moving parts necessary for proper operation as specified by the manufacturer.
- (2) Inspection of the flame pattern or characteristics and adjustments necessary to minimize emissions of NO_x and CO.
- (3) Inspection of the air-to-fuel ratio control system and adjustments necessary to ensure proper calibration and operation as specified by the manufacturer.

**SECTION E. Source Group Restrictions.**

(b) The company shall maintain a permanently bound log book or other method approved by the Department. This log shall contain at a minimum, the following information.

- (1) The date of the tuning procedure
- (2) The name of the service company and technicians
- (3) The final operating rate or load
- (4) The final NO_x and CO emission rates
- (5) The final excess oxygen rate
- (6) Any other information required by this approval

(c) The annual adjustment for the boilers shall be in accordance with the EPA document "Combustion Efficiency Optimization Manual for Operations of Oil and Gas-Fired Boilers", September 1983 (EPA-340/1-83-023) or equivalent procedures approved in writing by the Department.

(d) All adjustments and optimization of the units must minimize pollution and be in accordance with good air pollution control practices.

II. Sources 401 (Soaking Pit Batteries 4-6) and 501A (#207 DCEAF)

(a) The permittee shall maintain and adhere to an operation and maintenance plan for Sources 401 and 501A, which shall address good operation and maintenance practices for the minimization of NO_x (both sources) and VOC emissions (Source 501A), and/or manufacturer's operating specifications, including, for Source 501A measures to minimize the ambient air infiltration into the direct evacuation hoods.

(b) The permittee shall maintain records of any maintenance or modifications performed on Sources 401 and 501A.

(c) The permittee shall calculate and record the actual annual NO_x and VOC emissions using appropriate emissions factors from U.S. EPA Publication AP-42 or appropriate alternative emission factors based on PADEP review, coupled with appropriate operational and thrupt data.

(d) The permittee shall maintain written documentation of the items in (a)-(c) above for five years. The records shall be made available to the Department upon written request pursuant to 25 Pa. Code §129.100(d) and (i).

III. Sources 124 (Caster Vents), 132A (44" Mill Hot Rolling Operations), 132B (28"/35" Mill Hot Rolling Operations), 132C (20" Mill Hot Rolling Operations), 501B (Ladle Refining Furnace) and 922 (Compressed Air System Freeze Protection)

(a) The permittee shall maintain and adhere to an operation and maintenance plan for Sources 124, 132A, 132B, 132C, 501B and 922, which shall address good operation and maintenance practices for the minimization of VOC emissions, and/or manufacturer's operating specifications.

(b) The permittee shall maintain records of any maintenance or modifications performed on Sources 124, 132A, 132B, 132C, 501B and 922.

(c) The permittee shall calculate and record the actual annual VOC emissions from Sources 124, 132A, 132B, 132C, 501B and 922 using appropriate emissions factors from U.S. EPA Publication AP-42 or appropriate alternative emission factors based on PADEP review, coupled with appropriate operational and thrupt data.

(d) The permittee shall maintain written documentation of the items in (a)-(c) above for five years. The records shall be made available to the Department upon written request pursuant to 25 Pa. Code §129.100(d) and (i).

Note: The case-by-case RACT 2 requirements in this group were SIP'd by EPA on 1/26/22. The following conditions in RACT 1 Group 13 were superseded by the case-by-case RACT 2 requirements of this group: 9-15, and 20.

*** **Permit Shield in Effect.** ***

**SECTION E. Source Group Restrictions.**

Group Name: 16

Group Description: 40 CFR 60, Subpart III Engine(s)

Sources included in this group

ID	Name
311A	WBF EMERGENCY GENERATOR

I. RESTRICTIONS.

No additional requirements exist except as provided in other sections of this permit including Section B (Title V General Requirements).

II. TESTING REQUIREMENTS.

No additional testing requirements exist except as provided in other sections of this permit including Section B (Title V General Requirements).

III. MONITORING REQUIREMENTS.

No additional monitoring requirements exist except as provided in other sections of this permit including Section B (Title V General Requirements).

IV. RECORDKEEPING REQUIREMENTS.

No additional record keeping requirements exist except as provided in other sections of this permit including Section B (Title V General Requirements).

V. REPORTING REQUIREMENTS.

No additional reporting requirements exist except as provided in other sections of this permit including Section B (Title V General Requirements).

VI. WORK PRACTICE REQUIREMENTS.

No additional work practice requirements exist except as provided in other sections of this permit including Section B (Title V General Requirements).

VII. ADDITIONAL REQUIREMENTS.**# 001 [25 Pa. Code §127.441]****Operating permit terms and conditions.**

Regulatory Changes

Individual sources within this source group that are subject to 40 CFR Part 60 Subpart III shall comply with all applicable requirements of the Subpart. 40 CFR 60.4 requires submission of copies of all requests, reports and other communications to both the Department and the EPA. The EPA copies shall be forwarded to:

Associate Director
 United States Environmental Protection Agency
 Region III, Enforcement & Compliance Assurance Division
 Air, RCRA and Toxics Branch (3ED21)
 Four Penn Center
 1600 John F. Kennedy Boulevard
 Philadelphia, Pennsylvania 19103-2852

The Department copies shall be forwarded to the DEP SCRO Air Quality Program Manager at wiveaver@pa.gov, unless otherwise directed in writing by DEP.

In the event that the Federal Subpart that is the subject of this Source Group is revised, the permittee shall comply with the revised version of the subpart, and shall not be required to comply with any provisions in this permit designated as having

**SECTION E. Source Group Restrictions.**

the subpart as their authority, to the extent that such permit provisions would be inconsistent with the applicable provisions of the revised subpart.

002 [40 CFR Part 60 Standards of Performance for New Stationary Sources §40 CFR 60.4200]**Subpart III - Standards of Performance for Stationary Compression Ignition Internal Combustion Engines****Am I subject to this subpart?**

60.4200(a) The provisions of this subpart are applicable to manufacturers, owners, and operators of stationary compression ignition (CI) internal combustion engines (ICE) and other persons as specified in paragraphs (a)(1) through (4) of this section. For the purposes of this subpart, the date that construction commences is the date the engine is ordered by the owner or operator.

60.4200(a)(1) [NA - NOT AN ENGINE MANUFACTURER]

60.4200(a)(2) Owners and operators of stationary CI ICE that commence construction after July 11, 2005, where the stationary CI ICE are:

60.4200(a)(2)(i) Manufactured after April 1, 2006, and are not fire pump engines, or

60.4200(a)(2)(ii) [NA - NOT FIRE PUMP ENGINES]

60.4200(a)(3) [NA - NOT MODIFIED OR RECONSTRUCTED]

60.4200(a)(4) The provisions of § 60.4208 of this subpart are applicable to all owners and operators of stationary CI ICE that commence construction after July 11, 2005.

60.4200(b) [NA - TEST CELL NOT INVOLVED]

60.4200(c) If you are an owner or operator of an area source subject to this subpart, you are exempt from the obligation to obtain a permit under 40 CFR part 70 or 40 CFR part 71, provided you are not required to obtain a permit under 40 CFR 70.3(a) or 40 CFR 71.3(a) for a reason other than your status as an area source under this subpart. Notwithstanding the previous sentence, you must continue to comply with the provisions of this subpart applicable to area sources.

60.4200(d) Stationary CI ICE may be eligible for exemption from the requirements of this subpart as described in 40 CFR part 1068, subpart C, except that owners and operators, as well as manufacturers, may be eligible to request an exemption for national security.

60.4200(e) [NA - NOT TEMPORARY REPLACEMENT UNITS]

[71 FR 39172, July 11, 2006, as amended at 76 FR 37967, June 28, 2011; 86 FR 34357, June 29, 2021]

003 [40 CFR Part 60 Standards of Performance for New Stationary Sources §40 CFR 60.4201]**Subpart III - Standards of Performance for Stationary Compression Ignition Internal Combustion Engines****What emission standards must I meet for non-emergency engines if I am a stationary CI internal combustion engine manufacturer?**

[NA - NOT AN ENGINE MANUFACTURER]

004 [40 CFR Part 60 Standards of Performance for New Stationary Sources §40 CFR 60.4202]**Subpart III - Standards of Performance for Stationary Compression Ignition Internal Combustion Engines****What emission standards must I meet for emergency engines if I am a stationary CI internal combustion engine manufacturer?**

[NA - NOT AN ENGINE MANUFACTURER]

005 [40 CFR Part 60 Standards of Performance for New Stationary Sources §40 CFR 60.4203]**Subpart III - Standards of Performance for Stationary Compression Ignition Internal Combustion Engines****How long must my engines meet the emission standards if I am a stationary CI internal combustion engine manufacturer?**

[NA - NOT AN ENGINE MANUFACTURER]

**SECTION E. Source Group Restrictions.**

**# 006 [40 CFR Part 60 Standards of Performance for New Stationary Sources §40 CFR 60.4204]
Subpart III - Standards of Performance for Stationary Compression Ignition Internal Combustion Engines
What emission standards must I meet for non-emergency engines if I am an owner or operator of a stationary CI internal combustion engine?**

[NA - UNITS ARE EMERGENCY]

**# 007 [40 CFR Part 60 Standards of Performance for New Stationary Sources §40 CFR 60.4205]
Subpart III - Standards of Performance for Stationary Compression Ignition Internal Combustion Engines
What emission standards must I meet for emergency engines if I am an owner or operator of a stationary CI internal combustion engine?**

60.4205(a) [NA - ENGINES 2007 MODEL YEAR OR LATER]

60.4205(b) Owners and operators of 2007 model year and later emergency stationary CI ICE with a displacement of less than 30 liters per cylinder that are not fire pump engines must comply with the emission standards for new nonroad CI engines in § 60.4202, for all pollutants, for the same model year and maximum engine power for their 2007 model year and later emergency stationary CI ICE.

60.4202 REQUIREMENTS

60.4202(a) Stationary CI internal combustion engine manufacturers must certify their 2007 model year and later emergency stationary CI ICE with a maximum engine power less than or equal to 2,237 KW (3,000 HP) and a displacement of less than 10 liters per cylinder that are not fire pump engines to the emission standards specified in paragraphs (a)(1) through (2) of this section.

60.4202(a)(1) [NA - UNIT(S) > 37 KW (50 HP)]

60.4202(a)(2) For engines with a rated power greater than or equal to 37 KW (50 HP), the Tier 2 or Tier 3 emission standards for new nonroad CI engines for the same rated power as described in 40 CFR part 1039, appendix I, for all pollutants and the smoke standards as specified in 40 CFR 1039.105 beginning in model year 2007.

NOTE: 688 KW (923 HP) UNIT HAS A CERTIFICATE OF CONFORMITY WITH THE 2014 MODEL YEAR STANDARDS. THESE ARE AS FOLLOWS:

NMHC + NOX: 6.4 g/kW-hr

CO: 3.5 g/kW-hr

PM: 0.2 g/kW-hr

40 CFR 1039.105

(a) The smoke standards in this section apply to all engines subject to emission standards under this part, except for the following engines:

(1) - (3) [NA - ENGINE DOES NOT MEET AN EXEMPTION]

(b) Measure smoke as specified in § 1039.501(c). Smoke from your engines may not exceed the following standards:

(1) 20 percent during the acceleration mode.

(2) 15 percent during the lugging mode.

(3) 50 percent during the peaks in either the acceleration or lugging modes.

END OF 60.4202 REQUIREMENTS

60.4205(c) [NA - NOT FIRE PUMP ENGINES]

60.4205(d) [NA - UNITS < 30 L/CYL]

60.4205(e) [NA - DOES NOT CONDUCT PERFORMANCE TESTS IN USE]

60.4205(f) [NA - NOT MODIFIED OR RECONSTRUCTED]

[71 FR 39172, July 11, 2006, as amended at 76 FR 37969, June 28, 2011; 86 FR 34358, June 29, 2021]

**SECTION E. Source Group Restrictions.**

**# 008 [40 CFR Part 60 Standards of Performance for New Stationary Sources §40 CFR 60.4206]
Subpart III - Standards of Performance for Stationary Compression Ignition Internal Combustion Engines
How long must I meet the emission standards if I am an owner or operator of a stationary CI internal combustion engine?**

Owners and operators of stationary CI ICE must operate and maintain stationary CI ICE that achieve the emission standards as required in § § 60.4204 and 60.4205 over the entire life of the engine.

[76 FR page 37969, June 28, 2011]

**# 009 [40 CFR Part 60 Standards of Performance for New Stationary Sources §40 CFR 60.4207]
Subpart III - Standards of Performance for Stationary Compression Ignition Internal Combustion Engines
What fuel requirements must I meet if I am an owner or operator of a stationary CI internal combustion engine subject to this subpart?**

60.4207(a) [Reserved]

60.4207(b) Beginning October 1, 2010, owners and operators of stationary CI ICE subject to this subpart with a displacement of less than 30 liters per cylinder that use diesel fuel must use diesel fuel that meets the requirements of 40 CFR 1090.305 for nonroad diesel fuel, except that any existing diesel fuel purchased (or otherwise obtained) prior to October 1, 2010, may be used until depleted.

[§1090.305: ULSD standards:

- (a) Overview. Except as specified in § 1090.300(a), diesel fuel must meet the ULSD per-gallon standards of this section.
- (b) Sulfur content. Maximum sulfur content of 15 ppm.
- (c) Cetane index or aromatic content. Diesel fuel must meet one of the following standards:
 - (1) Minimum cetane index of 40;
 - (2) Maximum aromatic content of 35 volume percent.

60.4207(c) [RESERVED]

60.4207(d) Beginning June 1, 2012, owners and operators of stationary CI ICE subject to this subpart with a displacement of greater than or equal to 30 liters per cylinder are no longer subject to the requirements of paragraph (a) of this section, and must use fuel that meets a maximum per-gallon sulfur content of 1,000 parts per million (ppm).

60.4207(e) [NA - NO NATIONAL SECURITY EXEMPTION]

[71 FR 39172, July 11, 2006, as amended at 76 FR 37969, June 28, 2011; 78 FR 6695, Jan. 30, 2013; 85 FR 78463, Dec. 4, 2020]

**# 010 [40 CFR Part 60 Standards of Performance for New Stationary Sources §40 CFR 60.4208]
Subpart III - Standards of Performance for Stationary Compression Ignition Internal Combustion Engines
What is the deadline for importing or installing stationary CI ICE produced in the previous model year?**

60.4208(a) After December 31, 2008, owners and operators may not install stationary CI ICE (excluding fire pump engines) that do not meet the applicable requirements for 2007 model year engines.

60.4208(b) [NA - UNITS >25 HP]

60.4208(c)-(g) [NA - UNITS ARE EMERGENCY]

60.4208(h) [NA - IMPORTATION NOT RELEVANT IN THIS CASE]

60.4208(i) The requirements of this section do not apply to owners or operators of stationary CI ICE that have been modified, reconstructed, and do not apply to engines that were removed from one existing location and reinstalled at a new location.

[Amended at 76 FR page 37969, June 28, 2011]

**SECTION E. Source Group Restrictions.**

**# 011 [40 CFR Part 60 Standards of Performance for New Stationary Sources §40 CFR 60.4209]
Subpart III - Standards of Performance for Stationary Compression Ignition Internal Combustion Engines
What are the monitoring requirements if I am an owner or operator of a stationary CI internal combustion engine?**

If you are an owner or operator, you must meet the monitoring requirements of this section. In addition, you must also meet the monitoring requirements specified in § 60.4211.

60.4209(a) If you are an owner or operator of an emergency stationary CI internal combustion engine that does not meet the standards applicable to non-emergency engines, you must install a non-resettable hour meter prior to startup of the engine.

60.4209(b) [NA - FILTER NOT INSTALLED TO COMPLY WITH REGULATION]

[Amended at 76 FR page 37969, June 28, 2011]

**# 012 [40 CFR Part 60 Standards of Performance for New Stationary Sources §40 CFR 60.4210]
Subpart III - Standards of Performance for Stationary Compression Ignition Internal Combustion Engines
What are my compliance requirements if I am a stationary CI internal combustion engine manufacturer?**

[NA - NOT AN ENGINE MANUFACTURER]

**# 013 [40 CFR Part 60 Standards of Performance for New Stationary Sources §40 CFR 60.4211]
Subpart III - Standards of Performance for Stationary Compression Ignition Internal Combustion Engines
What are my compliance requirements if I am an owner or operator of a stationary CI internal combustion engine?**

60.4211(a) If you are an owner or operator and must comply with the emission standards specified in this subpart, you must do all of the following, except as permitted under paragraph (g) of this section:

60.4211(a)(1) Operate and maintain the stationary CI internal combustion engine and control device according to the manufacturer's emission-related written instructions;

60.4211(a)(2) Change only those emission-related settings that are permitted by the manufacturer; and

60.4211(a)(3) Meet the requirements of 40 CFR part 1068, as they apply to you.

60.4211(b) [NA - ENGINES ARE 2007 MODEL YEAR OR LATER]

60.4211(c) If you are an owner or operator of a 2007 model year and later stationary CI internal combustion engine and must comply with the emission standards specified in § 60.4204(b) or § 60.4205(b), or if you are an owner or operator of a CI fire pump engine that is manufactured during or after the model year that applies to your fire pump engine power rating in table 3 to this subpart and must comply with the emission standards specified in § 60.4205(c), you must comply by purchasing an engine certified to the emission standards in § 60.4204(b), or § 60.4205(b) or (c), as applicable, for the same model year and maximum (or in the case of fire pumps, NFPA nameplate) engine power. The engine must be installed and configured according to the manufacturer's emission-related specifications, except as permitted in paragraph (g) of this section.

60.4211(d) [NA - NOT SUBJECT TO § 60.4204(c) OR § 60.4205(d)]

60.4211(e) [NA - NOT MODIFIED OR RECONSTRUCTED]

60.4211(f) If you own or operate an emergency stationary ICE, you must operate the emergency stationary ICE according to the requirements in paragraphs (f)(1) through (3) of this section. In order for the engine to be considered an emergency stationary ICE under this subpart, any operation other than emergency operation, maintenance and testing, and operation in non-emergency situations for 50 hours per year, as described in paragraphs (f)(1) through (3), is prohibited. If you do not operate the engine according to the requirements in paragraphs (f)(1) through (3), the engine will not be considered an emergency engine under this subpart and must meet all requirements for non-emergency engines.

60.4211(f)(1) There is no time limit on the use of emergency stationary ICE in emergency situations.

60.4211(f)(2) You may operate your emergency stationary ICE for the purpose specified in paragraph (f)(2)(i) of this

**SECTION E. Source Group Restrictions.**

section for a maximum of 100 hours per calendar year. Any operation for non-emergency situations as allowed by paragraph (f)(3) of this section counts as part of the 100 hours per calendar year allowed by this paragraph (f)(2).

60.4211(f)(2)(i) Emergency stationary ICE may be operated for maintenance checks and readiness testing, provided that the tests are recommended by federal, state or local government, the manufacturer, the vendor, the regional transmission organization or equivalent balancing authority and transmission operator, or the insurance company associated with the engine. The owner or operator may petition the Administrator for approval of additional hours to be used for maintenance checks and readiness testing, but a petition is not required if the owner or operator maintains records indicating that federal, state, or local standards require maintenance and testing of emergency ICE beyond 100 hours per calendar year.

60.4211(f)(2)(ii) - (iii) [RESERVED]

60.4211(f)(3) Emergency stationary ICE may be operated for up to 50 hours per calendar year in non-emergency situations. The 50 hours of operation in non-emergency situations are counted as part of the 100 hours per calendar year for maintenance and testing provided in paragraph (f)(2) of this section. Except as provided in paragraph (f)(3)(i) of this section, the 50 hours per calendar year for non-emergency situations cannot be used for peak shaving or non-emergency demand response, or to generate income for a facility to an electric grid or otherwise supply power as part of a financial arrangement with another entity.

60.4211(f)(3)(i) The 50 hours per year for non-emergency situations can be used to supply power as part of a financial arrangement with another entity if all of the following conditions are met:

60.4211(f)(3)(i)(A) The engine is dispatched by the local balancing authority or local transmission and distribution system operator;

60.4211(f)(3)(i)(B) The dispatch is intended to mitigate local transmission and/or distribution limitations so as to avert potential voltage collapse or line overloads that could lead to the interruption of power supply in a local area or region.

60.4211(f)(3)(i)(C) The dispatch follows reliability, emergency operation or similar protocols that follow specific NERC, regional, state, public utility commission or local standards or guidelines.

60.4211(f)(3)(i)(D) The power is provided only to the facility itself or to support the local transmission and distribution system.

60.4211(f)(3)(i)(E) The owner or operator identifies and records the entity that dispatches the engine and the specific NERC, regional, state, public utility commission or local standards or guidelines that are being followed for dispatching the engine. The local balancing authority or local transmission and distribution system operator may keep these records on behalf of the engine owner or operator.

60.4211(f)(3)(ii) [Reserved]

60.4211(g) If you do not install, configure, operate, and maintain your engine and control device according to the manufacturer's emission-related written instructions, or you change emission-related settings in a way that is not permitted by the manufacturer, you must demonstrate compliance as follows:

60.4211(g)(1) [NA - ENGINES >100 HP]

60.4211(g)(2) [NA - ENGINES > 500 HP]

60.4211(g)(3) If you are an owner or operator of a stationary CI internal combustion engine greater than 500 HP, you must keep a maintenance plan and records of conducted maintenance and must, to the extent practicable, maintain and operate the engine in a manner consistent with good air pollution control practice for minimizing emissions. In addition, you must conduct an initial performance test to demonstrate compliance with the applicable emission standards within 1 year of startup, or within 1 year after an engine and control device is no longer installed, configured, operated, and maintained in accordance with the manufacturer's emission-related written instructions, or within 1 year after you change emission-related settings in a way that is not permitted by the manufacturer. You must conduct subsequent performance testing every

**SECTION E. Source Group Restrictions.**

8,760 hours of engine operation or 3 years, whichever comes first, thereafter to demonstrate compliance with the applicable emission standards.

60.4211(h) The requirements for operators and prohibited acts specified in 40 CFR 1039.665 apply to owners or operators of stationary CI ICE equipped with AECDs for qualified emergency situations as allowed by 40 CFR 1039.665.

[71 FR 39172, July 11, 2006, as amended at 76 FR 37970, June 28, 2011; 78 FR 6695, Jan. 30, 2013; 81 FR 44219, July 7, 2016; 86 FR 34359, June 29, 2021; 87 FR 48605, Aug. 10, 2022]

014 [40 CFR Part 60 Standards of Performance for New Stationary Sources §40 CFR 60.4212]

Subpart III - Standards of Performance for Stationary Compression Ignition Internal Combustion Engines

What test methods and other procedures must I use if I am an owner or operator of a stationary CI internal combustion engine with a displacement of less than 30 liters per cylinder?

[NA - TESTING NOT REQUIRED FOR CERTIFIED UNITS WHICH ARE NOT ALTERED PER 60.4211(g)]

015 [40 CFR Part 60 Standards of Performance for New Stationary Sources §40 CFR 60.4213]

Subpart III - Standards of Performance for Stationary Compression Ignition Internal Combustion Engines

What test methods and other procedures must I use if I am an owner or operator of a stationary CI internal combustion engine with a displacement of greater than or equal to 30 liters per cylinder?

[NA - DISPLACEMENT <30 L/CYL]

016 [40 CFR Part 60 Standards of Performance for New Stationary Sources §40 CFR 60.4214]

Subpart III - Standards of Performance for Stationary Compression Ignition Internal Combustion Engines

What are my notification, reporting, and recordkeeping requirements if I am an owner or operator of a stationary CI internal combustion engine?

60.4214(a) [NA - UNITS ARE EMERGENCY]

60.4214(b) If the stationary CI internal combustion engine is an emergency stationary internal combustion engine, the owner or operator is not required to submit an initial notification. Starting with the model years in table 5 to this subpart, if the emergency engine does not meet the standards applicable to non-emergency engines in the applicable model year, the owner or operator must keep records of the operation of the engine in emergency and non-emergency service that are recorded through the non-resettable hour meter. The owner must record the time of operation of the engine and the reason the engine was in operation during that time.

60.4214(c) [NA - NOT REQUIRED TO HAVE A DIESEL PARTICULATE FILTER]

60.4214(d) [NA - ENGINES DO NOT OPERATE FOR THE PURPOSE SPECIFIED IN § 60.4211(f)(3) (NO FINANCIAL ARRANGEMENT WITH ANOTHER ENTITY)]

60.4214(e) Owners or operators of stationary CI ICE equipped with AECDs pursuant to the requirements of 40 CFR 1039.665 must report the use of AECDs as required by 40 CFR 1039.665(e).

[71 FR 39172, July 11, 2006, as amended at 78 FR 6696, Jan. 30, 2013; 81 FR 44219, July 7, 2016; 87 FR 48606, Aug. 10, 2022]

017 [40 CFR Part 60 Standards of Performance for New Stationary Sources §40 CFR 60.4218]

Subpart III - Standards of Performance for Stationary Compression Ignition Internal Combustion Engines

What parts of the General Provisions apply to me?

Table 8 to this subpart shows which parts of the General Provisions in § 60.1 through 60.19 apply to you.

*** **Permit Shield in Effect.** ***

**SECTION E. Source Group Restrictions.**

Group Name: 17

Group Description: 40 CFR Part 63, Subpart CCCCCC Requirements

Sources included in this group

ID	Name
140	MOTOR VEHICLE FUELING

I. RESTRICTIONS.

No additional requirements exist except as provided in other sections of this permit including Section B (Title V General Requirements).

II. TESTING REQUIREMENTS.

No additional testing requirements exist except as provided in other sections of this permit including Section B (Title V General Requirements).

III. MONITORING REQUIREMENTS.

No additional monitoring requirements exist except as provided in other sections of this permit including Section B (Title V General Requirements).

IV. RECORDKEEPING REQUIREMENTS.

No additional record keeping requirements exist except as provided in other sections of this permit including Section B (Title V General Requirements).

V. REPORTING REQUIREMENTS.

No additional reporting requirements exist except as provided in other sections of this permit including Section B (Title V General Requirements).

VI. WORK PRACTICE REQUIREMENTS.

No additional work practice requirements exist except as provided in other sections of this permit including Section B (Title V General Requirements).

VII. ADDITIONAL REQUIREMENTS.**# 001 [25 Pa. Code §127.441]****Operating permit terms and conditions.**

Regulatory Changes

Individual sources within this source group that are subject to 40 CFR Part 63 Subpart CCCCCC shall comply with all applicable requirements of the Subpart. 40 CFR 63.13(a) requires submission of copies of all requests, reports and other communications to both the Department and the EPA. The EPA copies shall be forwarded to:

Associate Director
 United States Environmental Protection Agency
 Region III, Enforcement & Compliance Assurance Division
 Air, RCRA and Toxics Branch (3ED21)
 Four Penn Center
 1600 John F. Kennedy Boulevard
 Philadelphia, Pennsylvania 19103-2852

The Department copies shall be forwarded to the DEP SCRO Air Quality Program Manager at wiveaver@pa.gov, unless otherwise directed in writing by DEP.

In the event that the Federal Subpart that is the subject of this Source Group is revised, the permittee shall comply with the revised version of the subpart, and shall not be required to comply with any provisions in this permit designated as having

**SECTION E. Source Group Restrictions.**

the subpart as their authority, to the extent that such permit provisions would be inconsistent with the applicable provisions of the revised subpart.

002 [40 CFR Part 63 NESHAPS for Source Categories §40 CFR 63.11111]**Subpart CCCCCC - National Emission Standards for Hazardous Air Pollutants for Gasoline Dispensing Facilities
Am I subject to the requirements in this subpart?**

63.11111(a) The affected source to which this subpart applies is each GDF that is located at an area source. The affected source includes each gasoline cargo tank during the delivery of product to a GDF and also includes each storage tank.

63.11111(b) If your GDF has a monthly throughput of less than 10,000 gallons of gasoline, you must comply with the requirements in § 63.11116.

63.11111(c) [NA - MONTHLY THRUPUT < 10,000 GALLONS]

63.11111(d) [NA - MONTHLY THRUPUT < 10,000 GALLONS]

63.11111(e) An affected source shall, upon request by the Administrator, demonstrate that their monthly throughput is less than the 10,000-gallon or the 100,000-gallon threshold level, as applicable. For new or reconstructed affected sources, as specified in § 63.11112(b) and (c), recordkeeping to document monthly throughput must begin upon startup of the affected source. For existing sources, as specified in § 63.11112(d), recordkeeping to document monthly throughput must begin on January 10, 2008. For existing sources that are subject to this subpart only because they load gasoline into fuel tanks other than those in motor vehicles, as defined in § 63.11132, recordkeeping to document monthly throughput must begin on January 24, 2011. Records required under this paragraph shall be kept for a period of 5 years.

63.11111(f) If you are an owner or operator of affected sources, as defined in paragraph (a) of this section, you are not required to obtain a permit under 40 CFR part 70 or 40 CFR part 71 as a result of being subject to this subpart. However, you must still apply for and obtain a permit under 40 CFR part 70 or 40 CFR part 71 if you meet one or more of the applicability criteria found in 40 CFR 70.3(a) and (b) or 40 CFR 71.3(a) and (b).

63.11111(g) [NA - THIS FACILITY DOES NOT DISPENSE AVIATION GASOLINE]

63.11111(h) Monthly throughput is the total volume of gasoline loaded into, or dispensed from, all the gasoline storage tanks located at a single affected GDF. If an area source has two or more GDF at separate locations within the area source, each GDF is treated as a separate affected source.

63.11111(i) If your affected source's throughput ever exceeds an applicable throughput threshold, the affected source will remain subject to the requirements for sources above the threshold, even if the affected source throughput later falls below the applicable throughput threshold.

63.11111(j) The dispensing of gasoline from a fixed gasoline storage tank at a GDF into a portable gasoline tank for the on-site delivery and subsequent dispensing of the gasoline into the fuel tank of a motor vehicle or other gasoline-fueled engine or equipment used within the area source is only subject to § 63.11116 of this subpart.

63.11111(k) [NA - OTHER FEDERAL RULE NOT APPLICABLE]

[Amended at 76 FR page 4181, Jan. 24, 2011]

003 [40 CFR Part 63 NESHAPS for Source Categories §40 CFR 63.11112]**Subpart CCCCCC - National Emission Standards for Hazardous Air Pollutants for Gasoline Dispensing Facilities
What parts of my affected source does this subpart cover?**

63.11112(a) The emission sources to which this subpart applies are gasoline storage tanks and associated equipment components in vapor or liquid gasoline service at new, reconstructed, or existing GDF that meet the criteria specified in § 63.11111. Pressure/Vacuum vents on gasoline storage tanks and the equipment necessary to unload product from cargo tanks into the storage tanks at GDF are covered emission sources. The equipment used for the refueling of motor vehicles is not covered by this subpart.

63.11112(b) [NA - SOURCE(S) ARE EXISTING]

**SECTION E. Source Group Restrictions.**

63.11112(c) [NA - SOURCE(S) ARE EXISTING]

63.11112(d) An affected source is an existing affected source if it is not new or reconstructed.

004 [40 CFR Part 63 NESHAPS for Source Categories §40 CFR 63.11113]

Subpart CCCCCC - National Emission Standards for Hazardous Air Pollutants for Gasoline Dispensing Facilities
When do I have to comply with this subpart?

63.11113(a) [NA - SOURCE(S) ARE EXISTING]

63.11113(b) If you have an existing affected source, you must comply with the standards in this subpart no later than January 10, 2011.

63.11113(c) If you have an existing affected source that becomes subject to the control requirements in this subpart because of an increase in the monthly throughput, as specified in § 63.11111(c) or § 63.11111(d), you must comply with the standards in this subpart no later than 3 years after the affected source becomes subject to the control requirements in this subpart.

63.11113(d) [NA - SOURCE(S) ARE EXISTING]

63.11113(e) [NA - MONTHLY THRUPUT < 10,000 GALLONS]

63.11113(f) [NA - NOT SUBJECT TO SUBPART ONLY BECAUSE OF LOADING GASOLINE INTO FUEL TANKS OTHER THAN THOSE IN MOTOR VEHICLES]

[73 FR page 1945, Jan. 10, 2008, as amended at 73 FR page 35944, June 25, 2008; 76 FR page 4181, Jan. 24, 2011]

005 [40 CFR Part 63 NESHAPS for Source Categories §40 CFR 63.11115]

Subpart CCCCCC - National Emission Standards for Hazardous Air Pollutants for Gasoline Dispensing Facilities
What are my general duties to minimize emissions?

Each owner or operator of an affected source under this subpart must comply with the requirements of paragraphs (a) and (b) of this section.

63.11115(a) You must, at all times, operate and maintain any affected source, including associated air pollution control equipment and monitoring equipment, in a manner consistent with safety and good air pollution control practices for minimizing emissions. Determination of whether such operation and maintenance procedures are being used will be based on information available to the Administrator which may include, but is not limited to, monitoring results, review of operation and maintenance procedures, review of operation and maintenance records, and inspection of the source.

63.11115(b) You must keep applicable records and submit reports as specified in § 63.11125(d) and § 63.11126(b).

[76 FR page 4182, Jan. 24, 2011]

006 [40 CFR Part 63 NESHAPS for Source Categories §40 CFR 63.11116]

Subpart CCCCCC - National Emission Standards for Hazardous Air Pollutants for Gasoline Dispensing Facilities
Requirements for facilities with monthly throughput of less than 10,000 gallons of gasoline.

63.11116(a) You must not allow gasoline to be handled in a manner that would result in vapor releases to the atmosphere for extended periods of time. Measures to be taken include, but are not limited to, the following:

63.11116(a)(1) Minimize gasoline spills;

63.11116(a)(2) Clean up spills as expeditiously as practicable;

63.11116(a)(3) Cover all open gasoline containers and all gasoline storage tank fill-pipes with a gasketed seal when not in use;

63.11116(a)(4) Minimize gasoline sent to open waste collection systems that collect and transport gasoline to reclamation and recycling devices, such as oil/water separators.

**SECTION E. Source Group Restrictions.**

63.11116(b) You are not required to submit notifications or reports as specified in § 63.11125, § 63.11126, or subpart A of this part, but you must have records available within 24 hours of a request by the Administrator to document your gasoline throughput.

63.11116(c) You must comply with the requirements of this subpart by the applicable dates specified in § 63.11113.

63.11116(d) Portable gasoline containers that meet the requirements of 40 CFR part 59, subpart F, are considered acceptable for compliance with paragraph (a)(3) of this section.

[Amended at 76 FR page 4182, Jan. 24, 2011]

**# 007 [40 CFR Part 63 NESHAPS for Source Categories §40 CFR 63.11117]
Subpart CCCCCC - National Emission Standards for Hazardous Air Pollutants for Gasoline Dispensing Facilities
Requirements for facilities with monthly throughput of 10,000 gallons of gasoline or more.**

[NA - MONTHLY THRUPUT < 10,000 GALLONS]

**# 008 [40 CFR Part 63 NESHAPS for Source Categories §40 CFR 63.11118]
Subpart CCCCCC - National Emission Standards for Hazardous Air Pollutants for Gasoline Dispensing Facilities
Requirements for facilities with monthly throughput of 100,000 gallons of gasoline or more.**

[NA - MONTHLY THRUPUT < 10,000 GALLONS]

**# 009 [40 CFR Part 63 NESHAPS for Source Categories §40 CFR 63.11120]
Subpart CCCCCC - National Emission Standards for Hazardous Air Pollutants for Gasoline Dispensing Facilities
What testing and monitoring requirements must I meet?**

63.11120(a) [NA - MONTHLY THRUPUT < 10,000 GALLONS]

63.11120(b) [NA - MONTHLY THRUPUT < 10,000 GALLONS: TABLE 1 DOES NOT APPLY]

63.11120(c) [NA - PERFORMANCE TESTING NOT REQUIRED]

63.11120(d) [NA - MONTHLY THRUPUT < 10,000 GALLONS: TABLE 2 DOES NOT APPLY]

[73 FR 1945, Jan. 10, 2008, as amended at 76 FR 4182, Jan. 24, 2011]

**# 010 [40 CFR Part 63 NESHAPS for Source Categories §40 CFR 63.11124]
Subpart CCCCCC - National Emission Standards for Hazardous Air Pollutants for Gasoline Dispensing Facilities
What notifications must I submit and when?**

[NA - MONTHLY THRUPUT < 10,000 GALLONS]

**# 011 [40 CFR Part 63 NESHAPS for Source Categories §40 CFR 63.11125]
Subpart CCCCCC - National Emission Standards for Hazardous Air Pollutants for Gasoline Dispensing Facilities
What are my recordkeeping requirements?**

63.11125(a) - (b) [NA - MONTHLY THRUPUT < 10,000 GALLONS]

63.11125(c) [NA - MONTHLY THRUPUT < 10,000 GALLONS: TABLE 2 DOES NOT APPLY]

63.11125(d) Each owner or operator of an affected source under this subpart shall keep records as specified in paragraphs (d)(1) and (2) of this section.

63.11125(d)(1) Records of the occurrence and duration of each malfunction of operation (i.e., process equipment) or the air pollution control and monitoring equipment.

63.11125(d)(2) Records of actions taken during periods of malfunction to minimize emissions in accordance with § 63.11115(a), including corrective actions to restore malfunctioning process and air pollution control and monitoring equipment to its normal or usual manner of operation.

[76 FR page 4183, Jan. 24, 2011]

**SECTION E. Source Group Restrictions.**

012 [40 CFR Part 63 NESHAPS for Source Categories §40 CFR 63.11126]

Subpart CCCCC - National Emission Standards for Hazardous Air Pollutants for Gasoline Dispensing Facilities

What are my reporting requirements?

[NA - PER 63.11116(b): MONTHLY THRUPUT < 10,000 GALLONS]

013 [40 CFR Part 63 NESHAPS for Source Categories §40 CFR 63.11130]

Subpart CCCCC - National Emission Standards for Hazardous Air Pollutants for Gasoline Dispensing Facilities

What parts of the General Provisions apply to me?

Table 3 to this subpart shows which parts of the General Provisions apply to you.

***** Permit Shield in Effect. *****



SECTION F. Alternative Operation Requirements.

No Alternative Operations exist for this Title V facility.

**SECTION G. Emission Restriction Summary.**

No emission restrictions listed in this section of the permit.

**SECTION H. Miscellaneous.**

#001

This permit includes the applicable sources & conditions of the following plan approvals and operating permits:

TV 22-05012 - issued 2/10/23,
 22-307-034B - Steelmaking, #207 DCEAF,
 22-307-005A - Pneumatic Conveying System #2,
 22-399-002 - Burn Off Oven,
 22-309-005A - Lime and Spar Injection System Lime Silo,
 22-310-014 - Pebble Lime Stone Storage Silo,
 22-02012 - RACT operating permit VOC/NOx,
 PA 22-05012A - Boiler 99 mmbtu/hr,
 PA 22-05012B - Boiler 27.7 mmbtu/hr, and
 PA 22-05012E - walking beam reheat furnace (ID 311).

This permit supersedes those permits.

#002

The following sources do not require any work practice standards or testing, monitoring, recordkeeping and reporting requirements:

- (a) Source ID 033a, Hot Water Heaters, natural gas fired, less than 0.1 mmbtu/hr. Also, water heaters and space heaters, natural gas fired, capacity each less than 0.1 mmbtu/hr, combined heat input less than 1 mmbtu/hr.
- (b) Source ID 133, Tundish Shake-out at Caster.
- (c) Source ID 134, Cooling Tower at Caster.
- (d) Source ID 135, Cooling Tower at Vacuum Degasser Water Treatment.
- (e) Source ID 140, Motor Vehicle Fueling (diesel).
- (f) Source ID 141, Bloom Grinding.
- (g) Source ID 930, Caster Building Chiller Units #1 and #2.
- (h) Source ID 931, Slag Laydown Operations.
- (i) Laboratory HCl Etch Line controlled by Scrubber, and the process vents.
- (j) Material storage (inside a structure) and road dust emissions.
- (k) Plantwide maintenance painting.
- (l) Sandblasting.
- (m) Maintenance welding.
- (n) Burning rigs.
- (o) Babbit melting.
- (p) Welding operations inside Boiler Shop controlled by cyclone.
- (q) Product slicing and analysis controlled by cyclone.
- (r) Hot saw blade sharpening.
- (s) Ladle repair station.
- (t) Slingot hot top removal.
- (u) Window airconditioning (A/C) units and chillers.
- (v) Automotive A/C units.
- (w) Bully heaters for heat.
- (x) The following Storage Tanks, product and capacity as listed:
 - T003 Diesel Oil Storage Tank, 17,000 gal.
 - T009 Recycled used Oil Storage Tank, 7,500 gal.
 - T011 and T012 Sodium Hypochlorite Water Treatment Storage Tanks, capacity 2,000 gal and 3,000 gal respectively.
 - New #6 or equivalent oil storage tank, capacity 29,600 gal.
- (aa) Installed per RFDs:
 - Natural gas fired Office Boiler, 1.99 mmbtu/hr (11/2004).
 - Two Head Hardening Boilers, 6.8 mmbtu/hr each, natural gas fired (5/2007).
 - Head Hardening Cooling Tower, 1,000 gpm forced draft water (5/2007).
 - Use of #2 fuel oil as backup fuel for two boilers, Source IDs 032A and 035A (3/11/15)

#003

The data listed in Section A and Section D, Site Inventory List columns 3 & 4, capacity and fuel/material are for descriptive purpose and are not limitations.

**SECTION H. Miscellaneous.**

#004

Title V Weekly Inspection Monitoring Protocol

On a weekly basis, a certified Method 9 reader will observe all visible areas of the plant from the observation point on the hill overlooking the plant that has been historically used for Method 9 observations of the Electric Arc Furnace (EAF) shop and other sources. If the person observes any emission point within the facility, which on initial observation appears to have opacity in excess of 20% or more, he will conduct a EPA Method 9 observation of that source for a period of at least 6 minutes. If during this time period, emissions are noted in excess of the requirements of 25 Pa. Code Section 123.41, a record of these observations will be maintained in accordance with the requirements of Section C, Conditions #011 and #013. In addition, the observer will look for the presence of fugitive emissions beyond the plant property boundaries from this vantage point. If these emissions are noted, a record of the observation will be maintained in accordance with the requirements of Section C, Condition #013.

Further, a trained observer will, once per week, travel the entire Route 230 boundary along the active areas of the facility and record any emissions observed crossing the facility boundary. If such emissions are noted, a record of the observation will be maintained in accordance with the requirements of Section C, Conditions #011 and #013. During the observer's travel along Route 230, he will note any unusual odors that he believes are emanating from the facility. These odors will be recorded in accordance with the requirements of Section C, Conditions #011 and #013.

If the melt shop is shutdown during daylight hours for a period of 7 days or more, no observations will be required during the week.

#005

The original Title V Permit Revision included deletion of the following sources:

(a) Sources Shut Down:

- Source ID 201A - Rail Mill Draw Furnace (prior permit No. 22-307-025).
- Source ID 202 - Rail Mill #1 Heat Furnace (prior permit No. 22-307-025).
- Source ID 923 - 201 Quench Oil Vat.
- Source ID 503 - AC EAF.
- Source ID 031 - Central Boiler #5 deactivated effective January 1, 2002.
- Source ID 032 - Central Boiler #2, shut down July 31, 2005.

(b) Sources sold to Dura-Bond Pipe LLC as part of the sale of the Pipe Mill:

- Source ID 125 - Pipe Mill Dravo Heater.
- Source ID 126 - Pipe Mill ID Curing Station.
- Source ID 136 - Pipe Mill Auto Welding.



***** End of Report *****
